

BANCADA 3 PATAMARES

AB0043

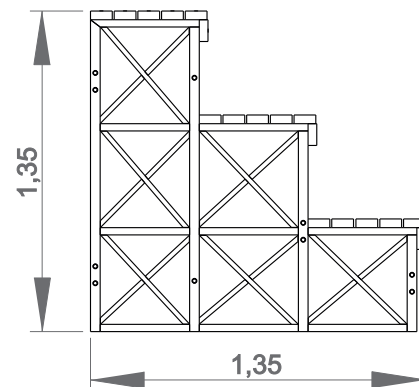

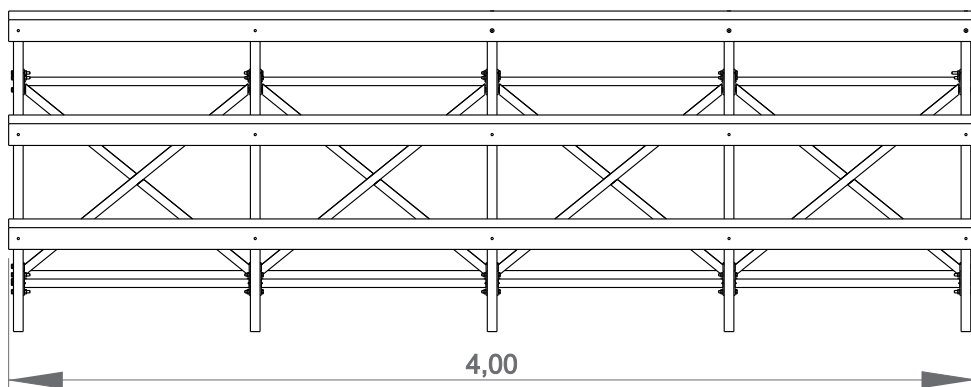
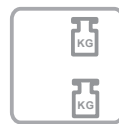
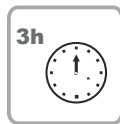
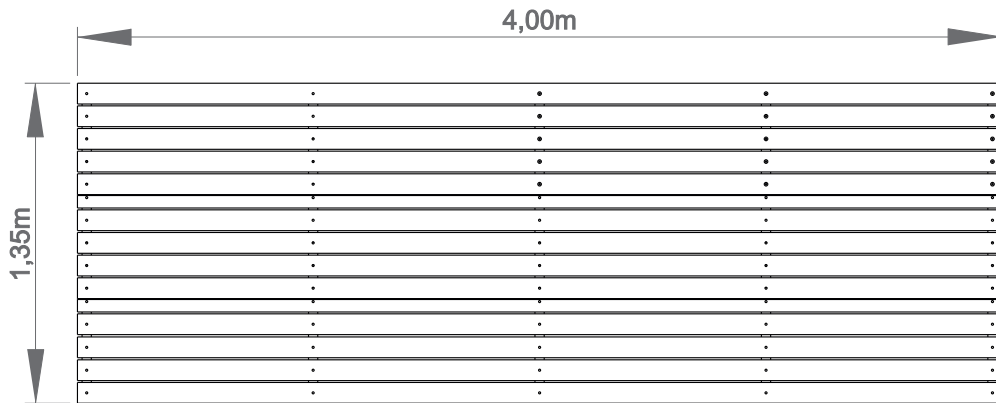

INFORMAÇÃO TÉCNICA / INFORMACIÓN TÉCNICA / TECHNICAL INFORMATION / INFORMATIONS TECHNIQUES

1 - Bancada c/ 3 patamares (24 lugares)

①

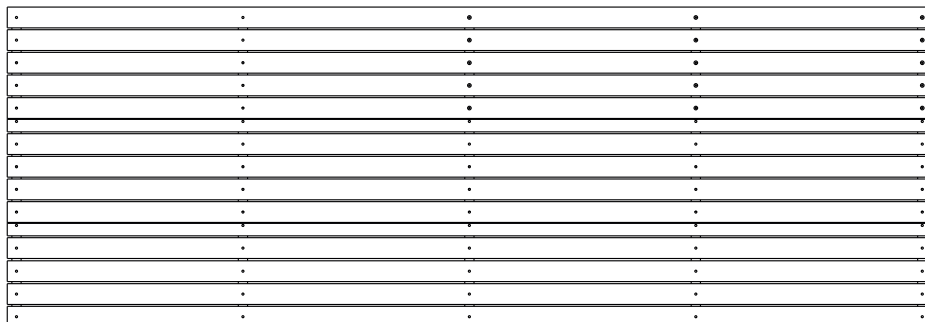



Assento

Madeira: Pinho laminado classificado com qualidade de garantia por controlo interno contínuo. Com tratamento autoclave, protegendo-a dos ataques de cogumelos, insectos e térmites. Acabamento final a tinta de base aquosa especialmente desenvolvida para proteger a madeira de humidades, intempéries e raios U.V.. Contém princípios activos que lhe conferem uma barreira protetora contra o aparecimento de fungos e bolores;

Peças Metálicas

Estrutura:

Ferro: Tratamento anticorrosivo de galvanização por imersão a quente de acordo com a norma EN ISO 1461;

Sistema de fixação

Tipo B – Sistema de fixação standard composto por base metálica aparafusada ao solo com buchas metálicas;

Parafusos e acessórios

Parafusos: Aço zincado ou opcionalmente aço inox AISI 304;



PROTECTORES DECORATIVOS:

Penetra profundamente na madeira destacando os veios e embelezando a madeira com os seus cores especiais transparentes

Muito resistente ao sol. Contém pigmentos micronizados absorventes e estabilizadores dos raios U.V.

PRINCÍPIOS ACTIVOS

Conferindo ao filme uma barreira protectora contra fungos e bolores

Microporoso, deixa respirar a madeira e evita as deformações naturais da madeira.

HIDRÓFUGO

protege contra a humidade, a chuva e impermeabiliza.

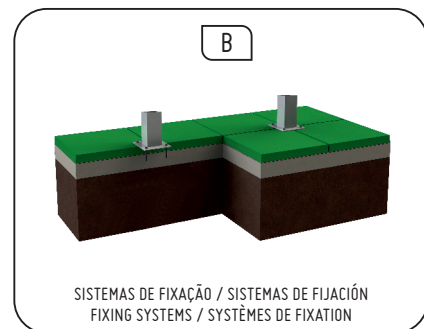



asiento

Madera: Pino laminado clasificado con calidad de garantía por control interno continuo. Con tratamiento autoclave, protegiéndola de los ataques de setas, insectos y termitas. Acabado final a tinta de base acuosa especialmente desarrollada para proteger la madera de humedad, intemperie y rayos U.V .. Contiene principios activos que le confieren una barrera protectora contra la aparición de hongos y mohos;

Piezas Metálicas

estructura:

Hierro: Tratamiento anticorrosivo de galvanización por inmersión en caliente de acuerdo con la norma EN ISO 1461;

Sistema de fijación

Tipo B – Sistema de fijación estándar compuesto por base metálica atornillada al suelo con tacos metálicos;

Tornillos y accesorios

Tornillos: Acero zincado o opcionalmente acero inoxidable AISI 304;

100%

PROTECTORES DECORATIVOS:

Penetra profundamente en la madera destacando los vetas y embellecer la madera con los sus colores especiales transparentes

Muy resistente al sol, contiene pigmentos microoxidados absorbentes y estabilizadores de los rayos U.V.

Microporoso, deja respirar la madera y evita las deformaciones naturales de la madera.

Fácil mantenimiento. No es necesario lijar o decapar para la aplicación de nuevas capas.

PRINCIPIOS ACTIVOS

que le da a la película una barrera protectora contra los hongos y los mohos

HIDRÓFUGO

protege contra la humedad, la lluvia e impermeabiliza.

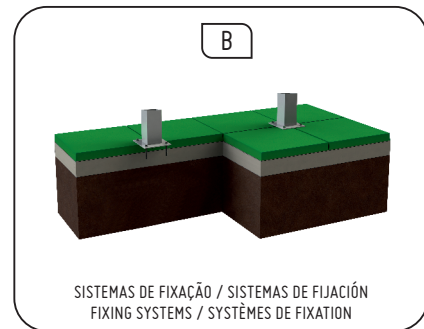



Seat

Wood: Laminated pine classified with guarantee quality by continuous internal control. With autoclave treatment, protecting it from attacks of mushrooms, insects and termites. Water-based paint finish specially developed to protect wood from moisture, weather and U.V. rays. Contains active principles that give it a protective barrier against the appearance of fungi and molds;

Metal parts

Structure:

Iron: Anticorrosive hot dip galvanizing treatment according to EN ISO 1461;

Fixation System







Type B - Standard fastening system consisting of metal base bolted to the ground with metal bushings;

Screws and accessories

Screws: Zinc-plated steel or optionally AISI 304 stainless steel;



DECORATIVE PROTECTORS:

 <p>Penetrates deep into wood highlighting and embellishing the wood with their special transparent colors</p>	 <p>Very resistant to sun. Contains absorbent micronized pigments and UV stabilizers.</p>	 <p>Microporous, let the wood breathe and prevents the natural deformations of the wood.</p>
 <p>Easy maintenance. No sanding or pickling is required for the application of new layers.</p>	<p>ACTIVE PRINCIPLES</p>  <p>Giving the film a protective barrier against fungi and molds</p>	<p>WATER-REPELLENT</p>  <p>protects against moisture, rain and waterproof.</p>

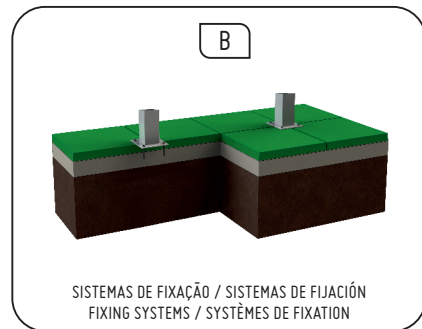

Siège

Bois: Pin laminé classé avec garantie de qualité par contrôle interne continu. Avec traitement autoclave, le protège des attaques de champignons, insectes et termites. Finition à base d'eau spécialement conçue pour protéger le bois de l'humidité, des intempéries et des rayons UV, contenant des principes actifs lui conférant une barrière protectrice contre l'apparition de moisissures et de moisissures;

Pièces en métal

Structure:

Fer: traitement anticorrosion par immersion à chaud selon la norme EN ISO 1461;

Système de fixation







Type B – Système de fixation standard constitué d'une base en métal boulonnée au sol avec des bagues en métal;

Vis et accessoires

Vis: Acier zingué ou, éventuellement, acier inoxydable AISI 304;

100% 

PROTECTEURS DÉCORATIFS:

 <p>Pénètre profondément dans le bois en soulignant les veines et en embellissant le bois avec ses couleurs transparentes spéciales</p>  <p>Facile d'entretien. Auc un ponçage ou décapage n'est requis pour l'application de nouvelles couches.</p>	 <p>Très résistant au soleil il contient des pigments microencapsulés d'absorption des stabilisants U.V.</p> <p>PRINCIPES ACTIFS</p>  <p>Donnant au film une barrière protectrice contre les champignons et les moisissures</p>	 <p>Microporeux, laisse respirer le bois et empêche les déformations naturelles du bois.</p> <p>HYDROFUGUE</p>  <p>protège contre l'humidité, la pluie et imperméable.</p>
--	--	---

