

# TORRE GIRATÓRIA

B0100109

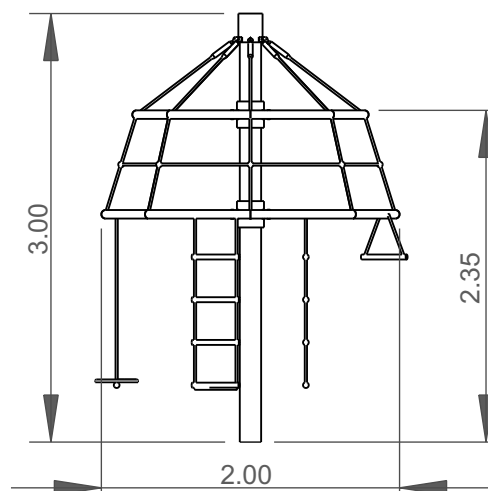
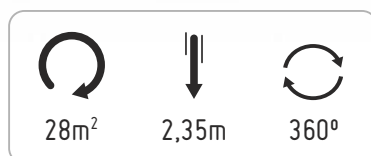

— Zona de impacto

- - Espaço livre

EN 1176-1

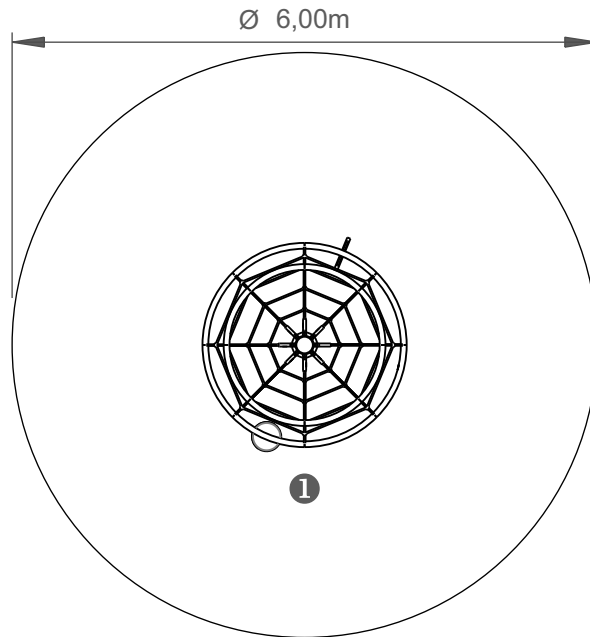

.....	1
	2.35
	28
	28

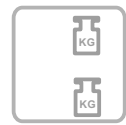
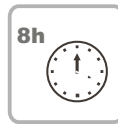
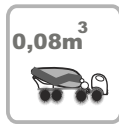

INFORMAÇÃO TÉCNICA / INFORMACIÓN TÉCNICA / TECHNICAL INFORMATION / INFORMATIONS TECHNIQUES

1 - Torre Giratória 2.35m

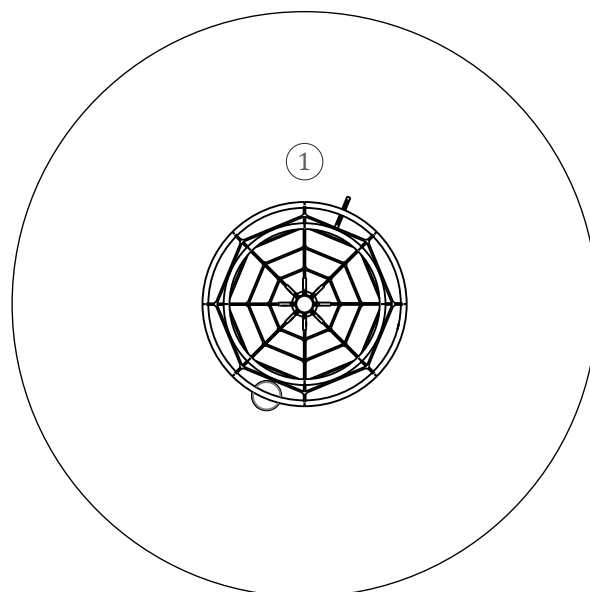



#### Rede

cordas Ø18mm reforçadas em aço revestido por fibras de polipropileno, acessórios de ligação e fixação em plástico HDPE com protecção U.V., elementos de fixação em aço galvanizado a quente;

#### Peças Metálicas

Tubos:

Aço Inox: AISI 304;

#### Sistema de fixação

Tipo C – Sistema de fixação standard composto por prumo aplicado directamente no solo e chumbado com betão;

#### Parafusos e acessórios

Parafusos: Aço zincado ou opcionalmente aço inox AISI 304;

Cápsulas: Plástico polipropileno PP;

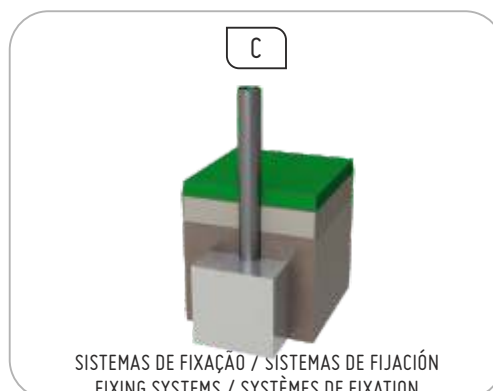



Divertir: Enquanto se divertem, as crianças adquirem imensas capacidades, desde habilidades físicas a interações sociais.



Socializar: A socialização e a imaginação são necessárias em todo o jogo. Tudo isso cria relação entre crianças e desperta o senso de convivência e a solidariedade.



Jogar: Desenvolve a paciência, a partilha e o espírito desportivo.



Trepar: Desenvolve as capacidades motrizes das crianças, o controlo do próprio corpo, o equilíbrio e a coordenação, estimulando a capacidade motora e a força nos movimentos.



#### Red

Cuerdas  $\varnothing$  18 mm reforzadas con acero revestido con fibras de polipropileno, accesorios de enlace y fijación de plástico HDPE con protección U.V., elementos de sujeción de acero galvanizado en caliente.

#### Piezas metálicas

Tubos:

Acero Inoxidable: AISI 304;

#### Sistema de fijación

TIPO C – Sistema de fijación estándar compuesto por poste hormigonado directamente en el suelo.

#### Tornillería y accesorios

Tornillos: Acero galvanizado electrolítico u opcionalmente acero inoxidable AISI 304;

Cápsulas: Plástico de polipropileno PP;

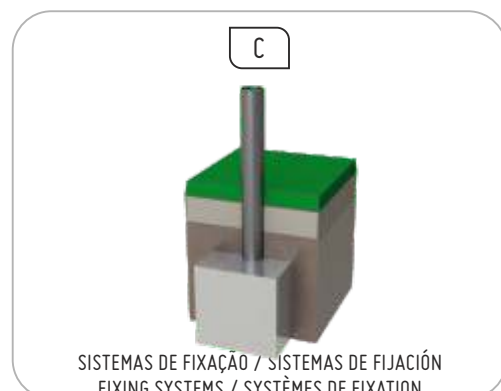



## FUNÇÕES LÚDICAS / FUNCIONES LÚDICAS / RECREATIONAL FUNCTIONS / FONCTIONS RÉCRÉATIVES



Divertir: Los niños, mientras se divierten, desarrollan una parte importante de sus capacidades, ya sean físicas, psicomotoras hasta interacciones sociales.



Socializar: Desarrollar la Socialización e imaginación son capacidades necesarias en los juegos de los niños; lo que conlleva a una relación interactiva entre ellos, despertando su sentido de convivencia y solidaridad.



Jugar: Desarrolla la tolerancia, el aprender a compartir, así como su espíritu deportivo.



Trepar: Se trata de un ejercicio idóneo para el desarrollo de las habilidades motrices de los niños, del control de su propio cuerpo, equilibrio y coordinación; estimulando, de esta manera, su capacidad motora y la seguridad en sus movimientos.



#### Net

Ø18mm strands reinforced in steel covered by polypropylene fibers, HDPE plastic attachment and attachment accessories with UV protection, hot galvanized steel fastening elements;

#### Metal parts

Pipes: Stainless Steel: AISI 304;

#### Fixation System

Type C – Standard fixing system composed of plumbing applied directly to the ground and cast with concrete;

#### Screws and accessories

Screws: Zinc-plated steel or optionally AISI 304 stainless steel;

Capsules: PP polypropylene plastic;

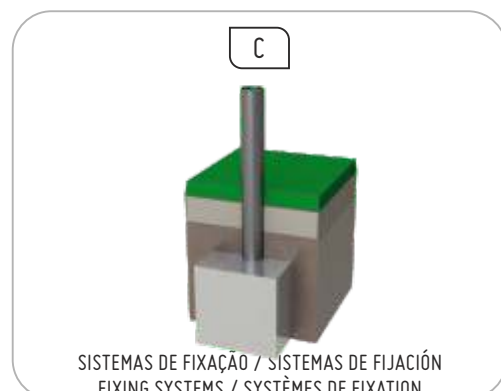



## FUNÇÕES LÚDICAS / FUNCIONES LÚDICAS / RECREATIONAL FUNCTIONS / FONCTIONS RÉCRÉATIVES



Fun: While having fun, children acquire immense abilities, from physical abilities to social interactions.



Socialize: Socialization and imagination are necessary throughout the game. All this creates a relationship between children and awakens the sense of coexistence and solidarity.



Play: Develops patience, sharing and sporting spirit.



Climb: It develops children's motor skills, body control, balance and coordination, stimulating motor ability and strength in movements.



#### Filet

Cordes de Ø18mm renforcés en acier recouvert de fibres de polypropylène, fixation en plastique PEHD et accessoires de fixation avec protection UV, éléments de fixation en acier galvanisé à chaud;

#### Pièces métalliques

Tuyaux: acier inoxydable: AISI 304;

#### Système de fixation

Type C – Système de fixation standard composé d'une plomberie appliquée directement au sol et coulée avec du béton;

#### Vis et accessoires

Vis: Acier zingué ou, éventuellement, acier inoxydable AISI 304;

Capsules: polypropylène PP;

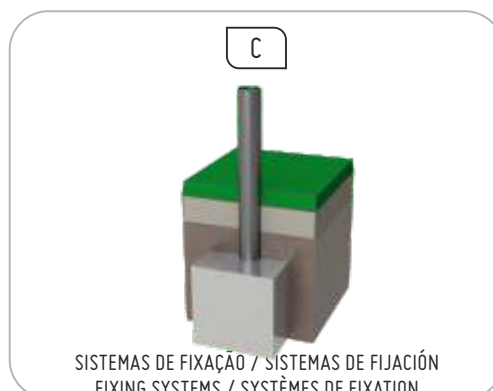



Amuser: tout en s'amusant, les enfants acquièrent d'énormes capacités, allant des capacités physiques aux interactions sociales.



Socialiser: la socialisation et l'imagination sont nécessaires tout au long du jeu. Tout cela crée une relation entre les enfants et éveille le sentiment de coexistence et de solidarité.



Jouer: Développe la patience, le partage et l'esprit sportif.



Escalader: développe les capacités motrices, le contrôle du corps, l'équilibre et la coordination des enfants, stimulant la capacité motrice et la force dans les mouvements.