

Tolerância Geral: ± 5%

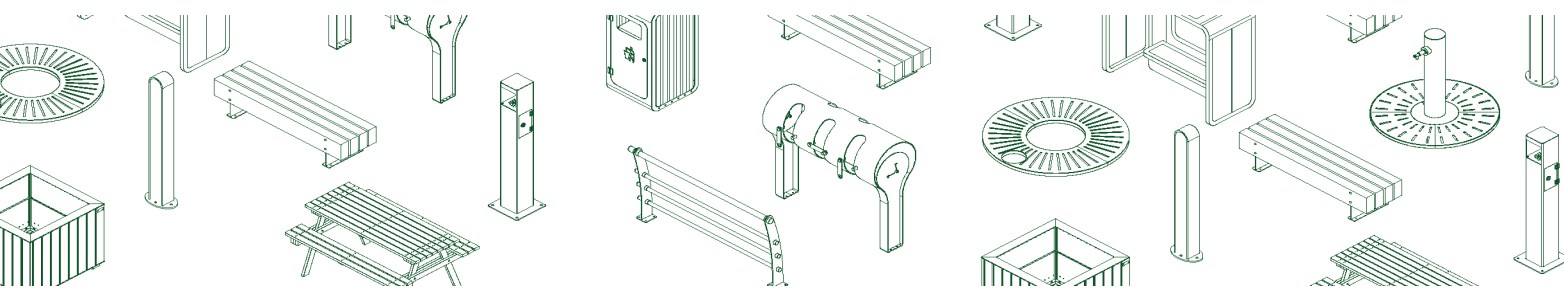

PORTUGAL
www.bragmaia.com
geral@bragmaia.com



brag
SPORT

brag
SIGN

brag
PLAY



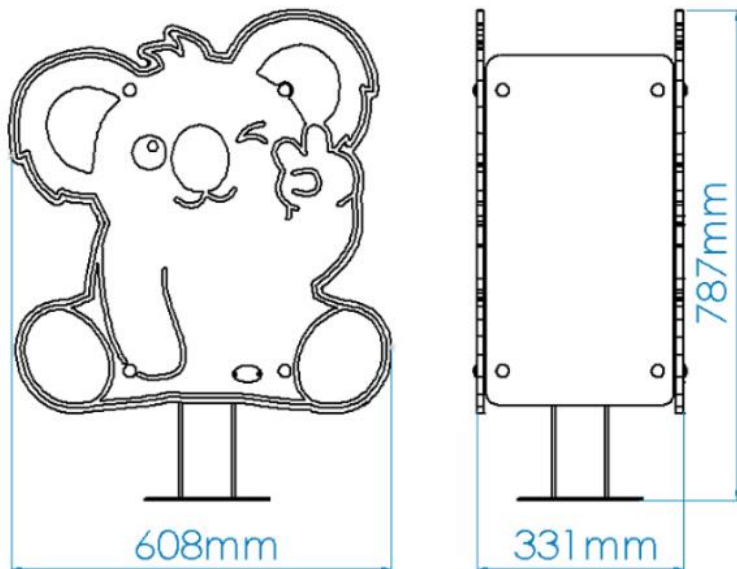

brag
URBAN

brag
LIGHT

MEDIDAS GERAIS / MEDIDAS / MEASURES / MESURES



ACESSÓRIOS / ACCESORIOS / ACCESSORIES / ACCESSOIRES

4,0 x		012512100000	ANILHA CHAPA FERRO ZINCADA D125 M10
4,0 x		057112101000	PARAF.TIREFOND FERRO ZINC.D571 10X100
4,0 x		50177	FIXADOR S12 R100 CX.100
4,0 x		BRCB001	BASE RETA P/CAPSULA BRAGMAIA
4,0 x		CBCRB001	CAPSULA "TAMPA" P/BASE RETA E CURVA BRAGMAIA



0,09m³



01:00h



2x



5,00kg



22,00kg

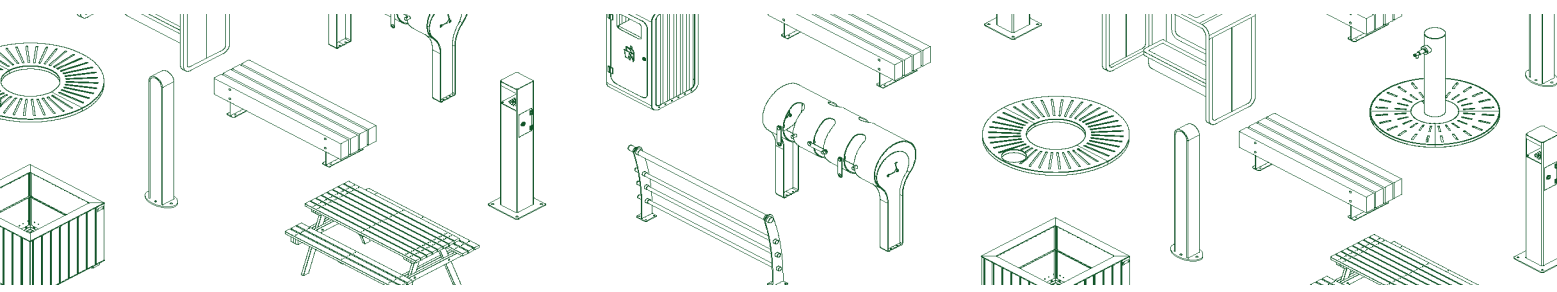

PORTUGAL
www.bragmaia.com
geral@bragmaia.com



brag **SPORT** brag **SIGN** brag **PLAY** brag **URBAN** brag **LIGHT**

VARIANTES / VARIANTES / VARIANTS / VARIANTES



EJRPAN001-B

PAPELEIRA PANDA APOIO B



EJRPAN001-X

PAPELEIRA PANDA APOIO X



EJRPING001-B

PAPELEIRA PINGUIM APOIO B



EJRPING001-X

PAPELEIRA PINGUIM APOIO X



MURBP1200-B

BANCO PANDA EM HDPE 1400X520X520MM
APOIO B



MURBP1200-X

BANCO PANDA EM HDPE 1400X520X520MM
APOIO X

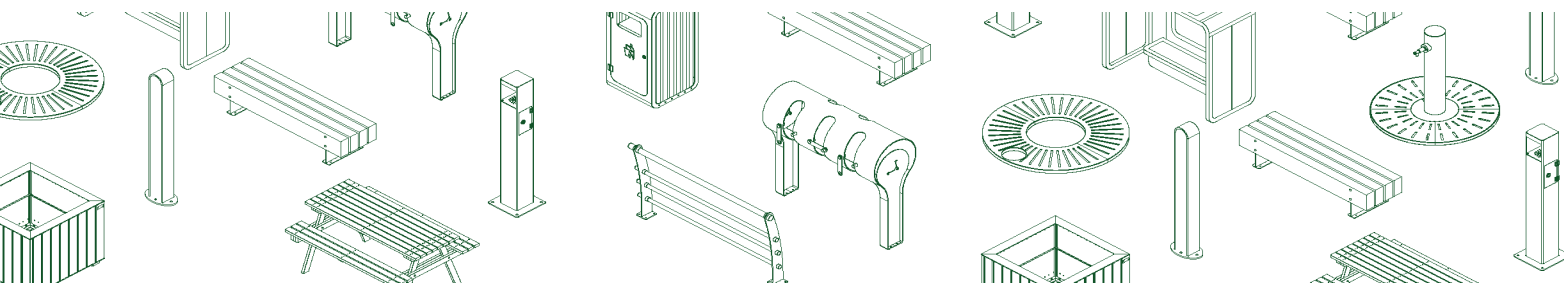

PORTUGAL
www.bragmaia.com
geral@bragmaia.com



brag **SPORT** brag **SIGN** brag **PLAY** brag **URBAN** brag **LIGHT**



DESCRIÇÃO

Equipamento BragPlay, papelreira KOALA, composto por estrutura em chapa de aço carbono decapado, com tratamento primário à base de zinco C5 e acabamento lacado ao RAL cinza forja 600 deep blue, à temperatura de 230° e chapa galvanizada e revestida a BragPo. Cuba quadrada extraível em chapa com 34L.

Ferragens em aço eletrozincado.

Fixação ao solo tipo X (aparafusar). Fixadores ao solo opcionais.

Medidas gerais (CxLxA): 60x331x787mm

CARACTERÍSTICAS TÉCNICAS

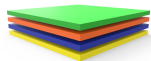

BRAGPO

BRAGPO HDPE de alta densidade monocolor ou bicolor, livre de HPA. Caracterizado pela sua extrema leveza e elasticidade, resistência a produtos químicos, corrosão, raios UV (UNE EN ISO 4892), alta resistência à inflamabilidade (UNE-EN ISO 11925-2) e resistência a impactos (ISO 527-1). Não necessita de qualquer manutenção.

Garantia: 15 anos



FERRAGENS EM AÇO ELETROZINCADO

Ferragens em aço eletrozincado, protegidas por cápsulas em polipropileno PP.



TUBO AÇO GALVANIZADO

Tubo (EN 10305-3) laminado a quente (EN 10027-1 e CR 10260), em aço galvanizado DX51D+Z275, de acordo com a norma EN 10346.

Garantia: 15 anos



CUBA

Fabricada em chapa de aço lisa de 1mm de espessura (EN 10327) de aço laminado a quente (EN 10027-1 e CR 10260), em aço galvanizado DX51D com revestimento Z200, de acordo com a norma EN 10346.

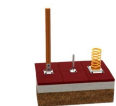

SISTEMA DE FIXAÇÃO

Tipo X - Sistema de fixação composto por base metálica aparafusada ao solo rígido.

A base metálica é fabricada em chapa de aço carbono, com tratamento anticorrosivo de galvanização por imersão a quente com espessura entre 120 a 140µm de acordo com a norma EN ISO 1461, que permite a sua colocação sem que o prumo entre em contacto direto com o solo. A sua fixação ao prumo é feita por um sistema de aperto rápido aumentando a longevidade do prumo e a sua fácil e rápida substituição em caso de necessidade.

CONFIDENCIALIDADE E PROPRIEDADE INTELECTUAL

A informação contida neste documento é confidencial, não podendo o destinatário do mesmo reproduzi-la ou permitir a terceiros que a obtenham, utilizem ou divulguem sem a prévia e expressa autorização da BRAGMAIA.

Todos os direitos de propriedade intelectual sobre os desenhos e modelos apresentados são da titularidade exclusiva da BRAGMAIA, sendo expressamente proibida a prática de qualquer ato de exploração dos mesmos sem o consentimento desta, nos termos do código da propriedade industrial e do código do direito de autor e dos direitos conexos. A violação da obrigação de confidencialidade e/ou dos direitos de propriedade intelectual da BRAGMAIA, pode dar origem a responsabilidade civil e criminal.

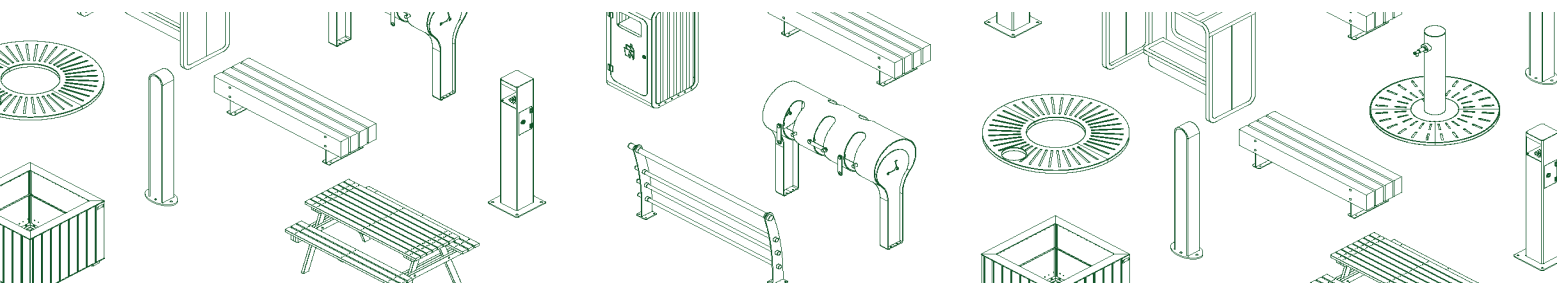

PORTUGAL
www.bragmaia.com
geral@bragmaia.com



brag
SPORT SIGN

brag
PLAY

brag
URBAN

brag
LIGHT



DESCRIPCIÓN

Equipamiento BragPlay, papelera "KOALA". Compuesto por estructura en chapa de acero carbono decapado, con tratamiento primario a base de zinc C5 y acabado lacado a RAL gris forja 600, deep blue, a una temperatura de 230°C y chapa galvanizada y revestida en BragPo. Cubeta cuadrada extraíble en chapa con una capacidad de 34L.

Herrajes de acero electrocincado.

Fijación al suelo Tipo X (atornillado). Fijadores al suelo opcionales.

Medidas generales (LxAxA): 60x331x787mm

CARACTERÍSTICAS TÉCNICAS

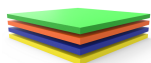

BRAGPO

BRAGPO HDPE de alta densidad monocolor o bicolor, sin HPA. Caracterizado por su extrema ligereza y elasticidad, resistencia a productos químicos, corrosión, rayos UV (UNE EN ISO 4892), a la inflamabilidad (UNE-EN ISO 11925-2) y al impacto (ISO 527-1). No necesita ningún tipo de mantenimiento.

Garantía: 15 años



HERRAJES EN ACERO ELECTROCHAPADO

Herrajes en acero electrochapado, protegidos por cápsulas en polipropileno PP.

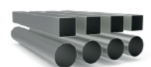

TUBO ACERO GALVANIZADO

Tubo (EN 10305-3), laminado en caliente (EN 10027-1 y CR 10260), en acero galvanizado DX51D+Z275, según la norma EN 10346.

Garantía: 15 años.



CUBETA

Fabricada en chapa de acero lisa de 1mm de espesor (EN 10327) de acero laminado en caliente (EN 10027-1 y CR 10260), en acero galvanizado DX51D con recubrimiento Z200, de acuerdo con la norma EN 10346.



SISTEMA DE FIJACIÓN

Tipo X - Sistema de fijación compuesto por una base metálica y atornillada al suelo rígido.

La base metálica es fabricada en chapa de acero al carbono, con tratamiento anticorrosivo de galvanización por inmersión en caliente con espesor entre 120 y 140µm de acuerdo con la norma EN ISO 1461, que permite su colocación sin que la viga entre en contacto directo con el suelo. Su fijación a la viga es hecha por un sistema de sujeción rápido aumentando la longevidad de la viga y su fácil y rápida sustitución en caso de necesidad.

CONFIDENCIALIDAD Y PROPIEDAD INTELECTUAL

La información contenida en este documento es estrictamente confidencial, no pudiendo el destinatario reproducirla o permitir a terceros que la adquieran, utilicen o divulguen sin la previa y expresa autorización de BRAGMAIA.

Todos los derechos de propiedad intelectual sobre los diseños y modelos presentados son de titularidad exclusiva de BRAGMAIA, estando expresamente prohibida la práctica de cualquier acto de usurpación de los mismos sin el previo consentimiento de la empresa, dentro de los términos del código de propiedad industrial y del código de derechos de autor y derechos análogos. La violación de la obligación de confidencialidad y/o de los derechos de propiedad intelectual de BRAGMAIA, puede dar origen a responsabilidad civil y criminal.

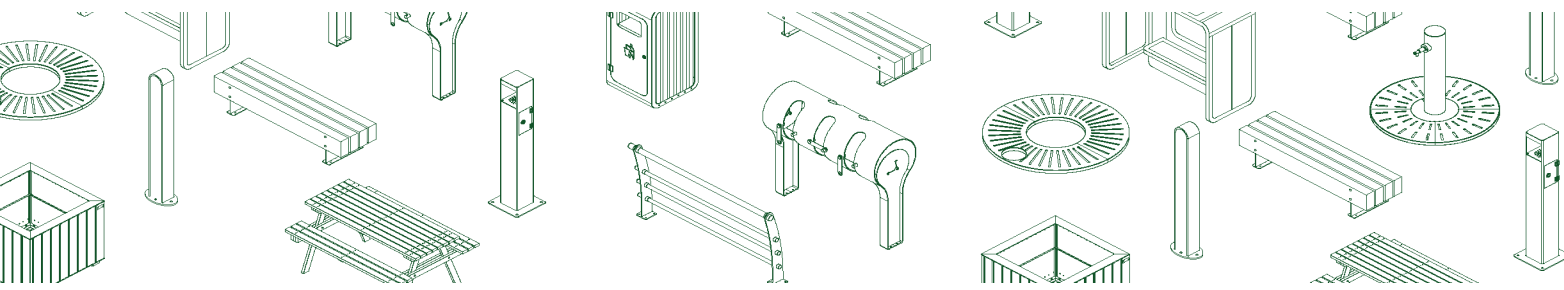

PORTUGAL
www.bragmaia.com
geral@bragmaia.com



brag **SPORT** brag **SIGN** brag **PLAY** brag **URBAN** brag **LIGHT**



DESCRIPTION

BragPlay equipment, KOALA litter bin, made up of a pickled carbon steel sheet structure, with C5 zinc-based primer treatment and RAL 600 Forge Grey / Deep Blue powder coated finish, at a temperature of 230° and BragPo-coated galvanised sheet metal. Removable square sheet metal tank with a capacity of 34L.

Electro-zinc plated steel hardware.

X-type ground fixing (screw). Optional floor fasteners.

Dimensions (LxWxH): 60x331x787mm

TECHNICAL FEATURES

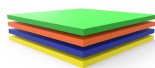

BRAGPO

BragPO HDPE of high density in one color or bicolor, free of HPA. Characterized by its extreme lightness and elasticity, resistance to chemicals, corrosion, UV rays (UNE EN ISO 4892), to flammability (UNE-EN ISO 11925-2) and impact (ISO 527-1). It doesn't need any maintenance.

Guarantee: 15 years.



STEEL ELECTROPLATED HARDWARE

Steel electroplated hardware, protected by polypropylene PP capsules.

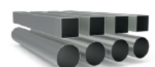

GALVANIZED STEEL TUBE

Tube (EN 10305-3), hot rolled (EN 10027-1 and CR 10260), in galvanized steel +Z275, according to EN 10346.

Guarantee: 15 years.



VESSEL

Made of 1 mm thick smooth steel plate (EN 10327) of hot rolled steel (EN 10027-1 and CR 10260), in galvanized steel DX51D with Z200 coating, according to EN 10346.

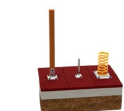

FIXATION SYSTEM

Type X - Fixation system composed of a metal base bolted to the hard ground.

The metal base is made of carbon steel sheet, with corrosion-resistant hot-dip galvanisation treatment of between 120 and 140µm thickness according to EN ISO 1461, which allows its placement without the plumb in direct contact with the ground. Its attachment to the plumb line is made by a quick clamping system increasing the longevity of the plumb line and its easy and fast replacement in case of need.

CONFIDENTIALITY AND INTELLECTUAL PROPERTY

The information contained in this document is confidential, and the recipient cannot reproduce it or allow third parties to obtain, use or disclose it without the prior and express authorization of BRAGMAIA.

All intellectual property rights over the designs and models presented are the exclusive property of BRAGMAIA, and the practice of any act of exploitation thereof without the consent of the latter, under the terms of the industrial property code and the copyright code and related rights. Violation of BRAGMAIA's obligation of confidentiality and / or intellectual property rights may give rise to civil and criminal liability.

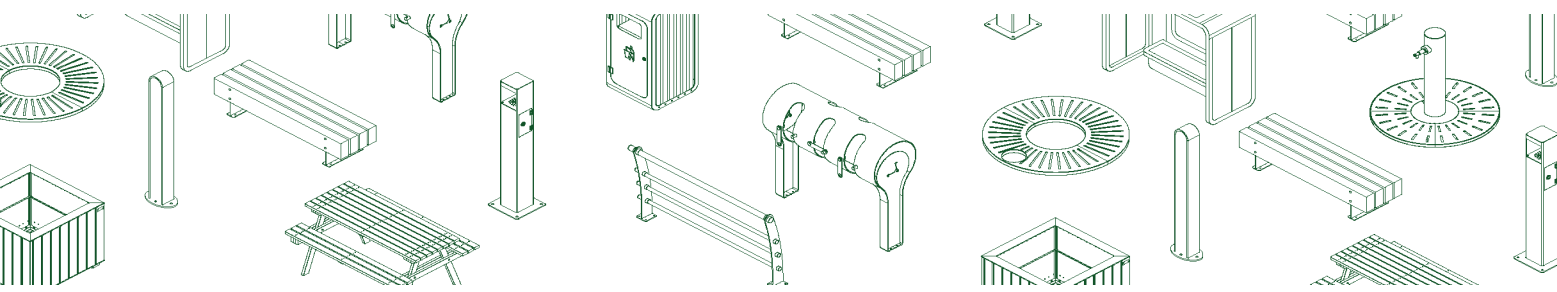

PORTUGAL
www.bragmaia.com
geral@bragmaia.com



brag **SPORT** brag **SIGN** brag **PLAY** brag **URBAN** brag **LIGHT**



DESCRIPTION

Équipement BragPlay, corbeille KOALA, composé d'une structure en tôle d'acier au carbone décapé, avec traitement d'apprêt zinc C5 et finition peinture thermolaquée en RAL 600 Gris fer forgé / Deep Blue, à une température de 230° et tôle galvanisée revêtue de BragPo. Bac carré amovible en tôle avec une capacité de 34L.

Visserie en acier électrozingué.

Fixation au sol de type X (visser). Éléments de fixation au sol en option.

Dimensions (Lxlxh): 60x331x787mm

CARACTÉRISTIQUES TECHNIQUES

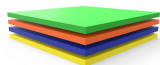

BRAGPO

BragPO HDPE d'une couleur ou bicolore de haute densité, sans HPA. Caractérisé par son extrême légèreté et élasticité, résistante aux produits chimiques, à la corrosion, aux rayons UV (UNE EN ISO 4892), à l'inflammabilité (UNE-EN ISO 11925-2) et aux impacts (ISO 527-1). Pas d'entretien nécessaire.

Garantie: 15 ans.



FERRURES EN ACIER ELECTROZINGÉ

Ferrures en acier électrozingué, protégé par des capsules en polypropylène PP.



TUBE EN ACIER GALVANISÉ

Tube (EN 10305-3), laminé à chaud (EN 10027-1 et CR 10260), en acier galvanisé DX51D+Z275, en accord avec la norme EN 10346.

Garantie: 15 ans.



CUVE

Fabriquée en tôle d'acier plat d'une épaisseur de 1 mm (EN 10327) en acier laminé à chaud (EN 10027-1 et CR 10260), en acier galvanisé DX51D recouvert de Z200, conformément à la norme EN 10346.



SISTÈME DE FIXATION

Type X - Système de fixation composé d'une base métallique fixée au sol rigide.

La base métallique est fabriquée en tôle d'acier carbone, avec un traitement anticorrosion par galvanisation par immersion à chaud d'une épaisseur comprise entre 120 et 140µm selon la norme EN ISO 1461, qui permet sa pose sans que la poutre rentre en contact direct avec le sol. Sa fixation à la poutre est réalisée par un système de serrage rapide augmentant sa longévité et facilitant son remplacement, qui sera rapide en cas de besoin.

CONFIDENTIALITÉ ET PROPRIÉTÉ INTELLECTUELLE

Les informations contenues dans ce document sont confidentielles et le destinataire ne peut pas les reproduire ni permettre à des tiers de les obtenir, de les utiliser ou de les divulguer sans l'autorisation préalable et expresse de BRAGMAIA.

Tous les droits de propriété intellectuelle sur les dessins et modèles présentés sont propriété exclusive de BRAGMAIA, et la pratique d'un acte d'exploitation de ceux-ci sans le consentement de cette dernière, selon les termes du code de la propriété industrielle et du code du droit d'auteur et des droits voisins.

La violation de l'obligation de confidentialité et / ou des droits de propriété intellectuelle de BRAGMAIA peut engager à la responsabilité civile et pénale.

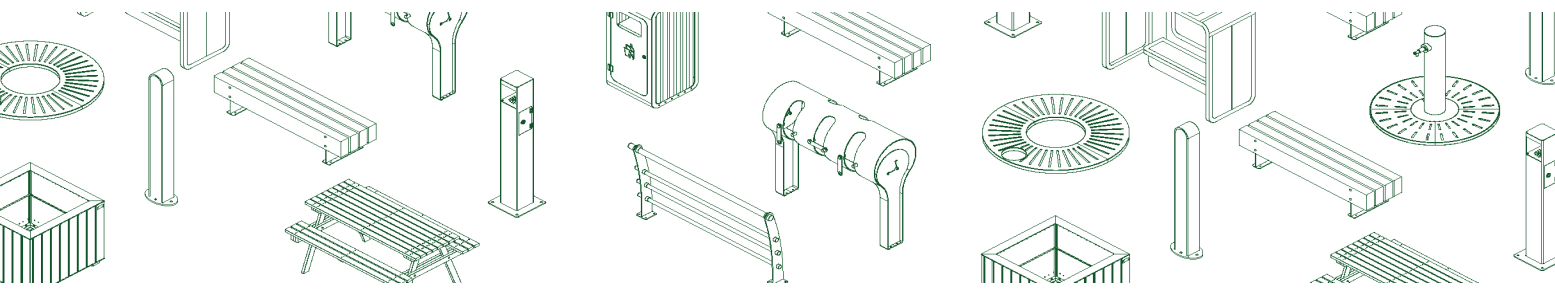

PORTUGAL
www.bragmaia.com
geral@bragmaia.com



brag **SPORT** brag **SIGN** brag **PLAY** brag **URBAN** brag **LIGHT**