





EUREMA

ELDAN058RC4-A



| | | | |
|---|---|---|--|
|  |  |  |  |
| 113m ² | 1.50m | 3-14 | 36 |

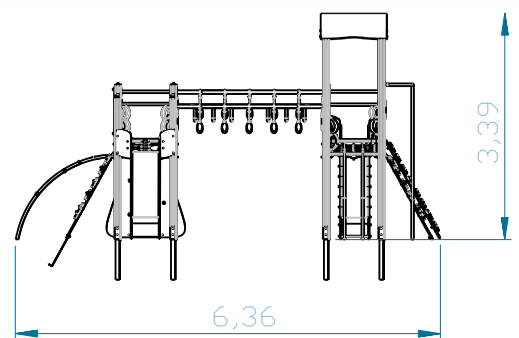
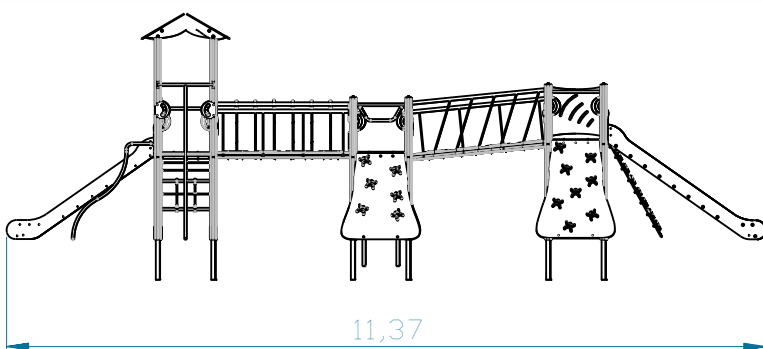

Utilização do equipamento sujeito a condições vigiadas; Zona de segurança: Área mínima requerida pela norma EN 1176-1,6
 Utilización del equipo sujeto a condiciones vigiladas; Zona de seguridad: Área mínima requerida por la norma EN 1176-1,6
 Use of equipment subject to supervised conditions; Safety zone: Minimum area required by EN 1176-1,6
 Utilisation d'équipement soumis à des conditions supervisées; Zone de sécurité: Surface minimale requise par l'EN 1176-1,6



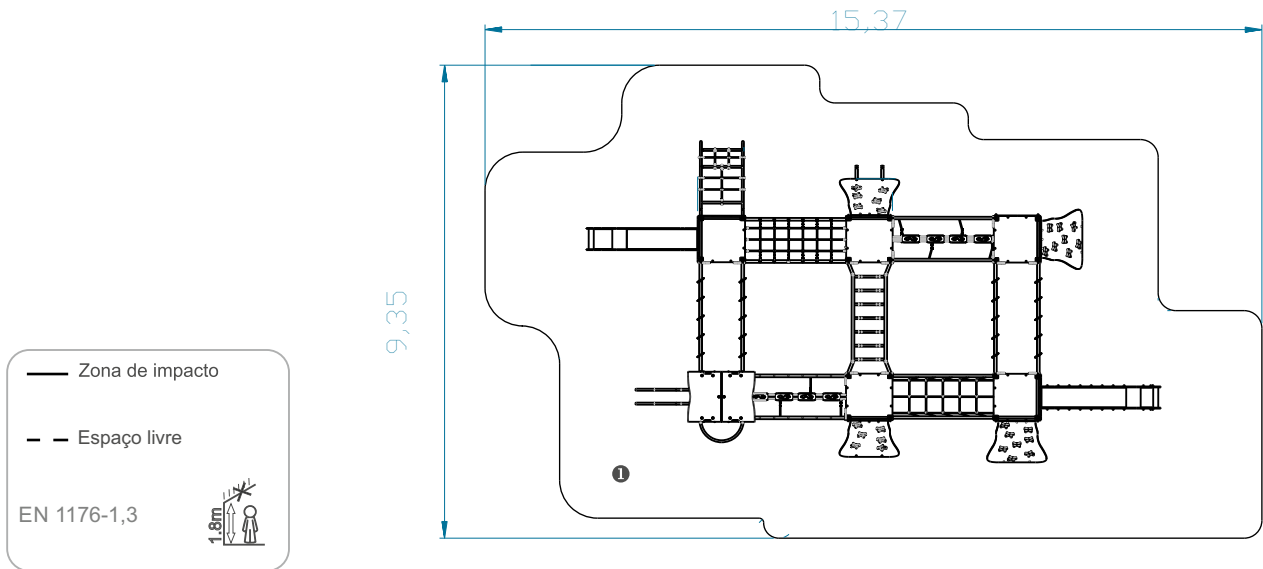

— Zona de impacto

- - - Espaço livre

EN 1176-1,3

| | |
|----------------|------|
| | ① |
| | 1,50 |
| | 113 |
| m ² | |

3.60m³

20h

2x

KG

KG

INFORMAÇÃO TÉCNICA / INFORMACIÓN TÉCNICA / TECHNICAL INFORMATION / INFORMATIONS TECHNIQUES

- 1 - Torre Simples 1.30m
- 2 - Torre Nuvem 1.30m
- 3 - Torre Simples 1.50m
- 4 - Escorrega INOX 1.50m
- 5 - Travessia Aérea 1.30m
- 6 - Trapézio 1.30m
- 7 - Trapézio 1.50m
- 8 - Ponte de Cordas 1.30m
- 9 - Ponte com Prumo 1.30m
- 10 - Escalada 1,30m
- 11 - Barão Bombeiro 1.30m
- 12 - Speed Gliss 1.30m
- 13 - Escalada de acesso 1.30m

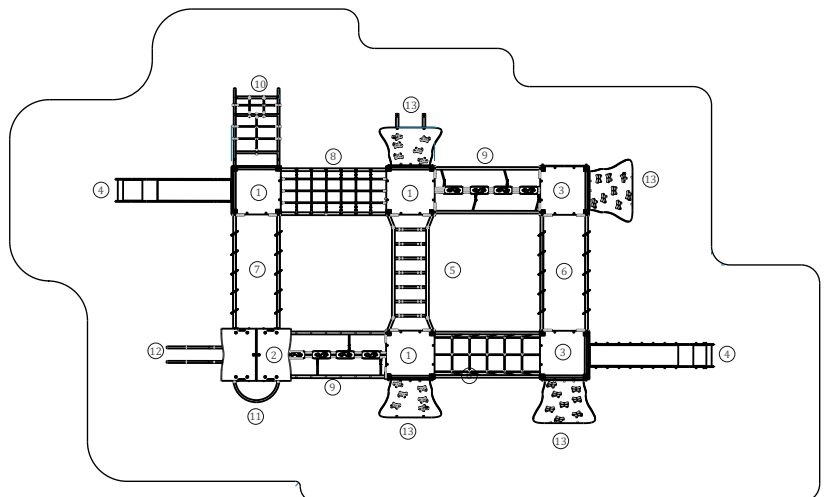

Utilização do equipamento sujeito a condições vigiadas; Zona de segurança: Área mínima requerida pela norma EN 1176-1,6
 Utilización del equipo sujeto a condiciones vigiladas; Zona de seguridad: Área mínima requerida por la norma EN 1176-1,6
 Use of equipment subject to supervised conditions; Safety zone: Minimum area required by EN 1176-1,6
 Utilisation d'équipement soumis à des conditions supervisées; Zone de sécurité: Surface minimale requise par l'EN 1176-1,6



Prumos

Madeira: Pinho laminado classificado com qualidade de garantia por controlo interno contínuo.

Com tratamento autoclave, protegendo-a dos ataques de cogumelos, insectos e térmites. Acabamento final a tinta de base aquosa especialmente desenvolvida para proteger a madeira de humidades, intempéries e raios U.V.. Contém princípios activos que lhe conferem uma barreira protetora contra o aparecimento de fungos e bolores;

Painéis

HDPE: Polietileno de alta densidade monocolor ou bicolor. Por ser um polímero é caracterizado pela sua resistência a produtos químicos e à corrosão. Pela sua capacidade de elasticidade e leveza, oferece alta resistência ao impacto, sendo muito difícil quebrar. A superfície antiderrapante fornece segurança para as crianças e a sua base sintética impede o cultivo de bactérias e fungos. Não necessita de qualquer manutenção;

Rede

cordas Ø16mm reforçadas em aço revestido por fibras de polipropileno, acessórios de ligação e fixação em plástico HDPE com protecção U.V., elementos de fixação em aço galvanizado a quente;

Contraplacado marítimo

antiderrapante, colado com resinas fenólicas resistentes as intempéries e raios UV. em conformidade com as normas EL 314-2/classe 3 (DIN 68 TS TCIL3: BFU 100, BS 6566 PART 8 : WBP);

Peças de Plástico

Túnel: Em tubo corrugado fabricado em polipropileno em conformidade com a norma EN 13476;

Peças Metálicas

Tubos:

Aço Inox: AISI 304 de Ø40mm e de Ø54mm;

Ferro: Com tratamento anticorrosivo de galvanização por imersão a quente de acordo com a norma EN ISO 1461;

Escorrega: Superfície deslizante: Chapa de Aço Inox AISI 304, dobrada e enrolada em uma só peça;

Sistema de fixação

Tipo A – Sistema de fixação standard composto por base metálica embutida no solo e chumbada com betão;

Parafusos e acessórios

Parafusos: Aço zincado ou opcionalmente aço inox AISI 304;

Cápsulas: Plástico polipropileno PP;



PROTECTORES DECORATIVOS:



Penetra profundamente na madeira destacando os veios e embelezando a madeira com as suas cores especiais transparentes.



Muito resistente ao sol. Contém pigmentos microcristalinos absorventes e estabilizadores dos raios U.V.



Microporos, deixa respirar a madeira e evita as deformações naturais da madeira.

PRINCÍPIOS ACTIVOS



Fácil manutenção. Não é necessário lixar ou decapar para a aplicação de novas camadas.



Conferindo ao filme uma barreira protectora contra fungos e bolores.



protege contra a humidade, a chuva e impermeabiliza.





Divertir: Enquanto se divertem, as crianças adquirem imensas capacidades, desde habilidades físicas a interações sociais.



Socializar: A socialização e a imaginação são necessárias em todo o jogo. Tudo isso cria relação entre crianças e desperta o senso de convivência e a solidariedade.



Jogar: Desenvolve a paciência, a partilha e o espírito desportivo.



Trepar: Desenvolve as capacidades motrizes das crianças, o controlo do próprio corpo, o equilíbrio e a coordenação, estimulando a capacidade motora e a força nos movimentos.



Escorregar: A superfície inclinada permite que a criança deslize a grande velocidade. A sensação de velocidade fá-la sentir viva e a aprender a controlar os movimentos exercitando os reflexos e as habilidades motoras.



Deslizar: Esta actividade proporciona uma sensação fascinante que por sua vez ajuda a desenvolver o equilíbrio e a coordenação estimulando o sistema nervoso.



Postes

Madera: Pino laminado clasificado con calidad de garantía por control interno continuo.

Con tratamiento autoclave, protegiéndola de los ataques de setas, insectos y termitas. Acabado final a tinta de base acuosa especialmente desarrollada para proteger la madera de humedad, intemperie y rayos U.V. .. Contiene principios activos que le confieren una barrera protectora contra la aparición de hongos y mohos;

paneles

HDPE: Polietileno de alta densidad, monocolor o bicolor. Al tratarse de un polímero, su resistencia a productos químicos y corrosión está garantizada. Su capacidad de elasticidad y levedad ofrece una alta resistencia a cualquier tipo de impacto, siendo muy difícil que se producen roturas. Su superficie antideslizante ofrece a los niños una alta seguridad y su base sintética impide el desarrollo de bacterias y hongos. No necesita ningún tipo de manutención.

red

Cuerdas \varnothing 16 mm reforzadas con acero revestido con fibras de polipropileno, accesorios de enlace y fijación de plástico HDPE con protección U.V., elementos de sujeción de acero galvanizado en caliente.

Madera contrachapada marítima

Antideslizante, pegado con resinas fenólicas resistentes a la intemperie y los rayos UV. de conformidad con las normas EL 314-2 / clase 3 (DIN 68 TS TCIL3: BFU 100, BS 6566 PART 8: WBP);

Piezas de plástico

Túnel: tubo corrugado de polipropileno conforme a la normativa EN 13476;

Piezas Metálicas

Tubos:

Acero Inoxidable: AISI 304 de \varnothing 40 mm y de \varnothing 54 mm.

Hierro: con tratamiento anticorrosivo galvanizado por inmersión en caliente de acuerdo con la normativa EN ISO 1461.

Tobogan: Superficie deslizante: Chapa de acero inoxidable AISI 304, doblada y enrollada en una sola pieza;

Sistema de fijación

Permite la colocación en el suelo sin que la madera entre en contacto con la tierra. La parte inferior de los sistemas de fijación se anclan en el suelo; estando fabricados en chapa de acero galvanizado:

Tipo A – Sistema de fijación estándar compuesto por base metálica embutida en el suelo y plomada con hormigón;

Tornillería y accesorios

Tornillos: Acero galvanizado electrolítico u opcionalmente acero inoxidable AISI 304;

Cápsulas: Plástico de polipropileno PP;



100%

 **PROTECTORES DECORATIVOS:**



Penetra profundamente na madeira destacando os veios e embelezando a madeira com os seus cores especiais transparentes



Muito resistente ao sol. Contém pigmentos micronizados absorventes e estabilizadores dos raios U.V.



Microporos, deixa respirar a madeira e evita as deformações naturais da madeira.

PRINCÍPIOS ACTIVOS



Fácil manutenção. Não é necessário lixar ou decapar para a aplicação de novas camadas.



Conferindo ao filme uma barreira protectora contra fungos e bolores



HIDRÓFUGO
protege contra a humidade, a chuva e impermeabiliza.





FUNÇÕES LÚDICAS / FUNCIONES LÚDICAS / RECREATIONAL FUNCTIONS / FONCTIONS RÉCRÉATIVES



Divertir: Mientras se divierten, los niños adquieren inmensas capacidades, desde habilidades físicas a interacciones sociales.



Socializar: La socialización y la imaginación son necesarias en todo el juego. Todo esto crea relación entre niños y despierta el sentido de convivencia y la solidaridad.



Jugar: Desarrolla la paciencia, el compartir y el espíritu deportivo.



Trepar: Desarrolla las capacidades motrices de los niños, el control del propio cuerpo, el equilibrio y la coordinación, estimulando la capacidad motora y la fuerza en los movimientos.



Deslizar: Esta actividad proporciona una sensación fascinante que a su vez ayuda a desarrollar el equilibrio y la coordinación estimulando el sistema nervioso.



Escurrir: La superficie inclinada permite que el niño deslice a gran velocidad. La sensación de velocidad la hace sentir viva y aprender a controlar los movimientos ejercitando los reflejos y las habilidades motoras.



Plums

Wood: Laminated pine classified with guarantee quality by continuous internal control.

With autoclave treatment, protecting it from attacks of mushrooms, insects and termites. Water-based paint finish specially developed to protect wood from moisture, weather and U.V. rays. Contains active principles that give it a protective barrier against the appearance of fungi and molds;

Panels

HDPE: High density polyethylene mono or two color. Being a polymer is characterized by its resistance to chemicals and corrosion. Due to its elasticity and lightness, it offers high impact resistance and is very difficult to break. The non-slip surface provides safety for children and its synthetic base prevents the growth of bacteria and fungi. It does not require any maintenance;

Net

ropes Ø16mm reinforced in steel covered by polypropylene fibers, fittings and connection in HDPE plastic with U.V. protection, fastening elements in hot galvanized steel;

Marine Plywood

anti-slip, bonded with weather resistant phenol resins and UV rays. in accordance with standards EL 314-2 / class 3 (DIN 68 TS TCIL3: BFU 100, BS 6566 PART 8: WBP);

Plastic parts

Tunnel: In corrugated tube made of polypropylene in accordance with EN 13476;

Metal parts

Tubes:

Sliding surface: AISI 304 stainless steel plate, folded and rolled in one piece;

Stainless Steel: AISI 304 of Ø40mm and Ø54mm;

Iron: With anticorrosive treatment of hot dip galvanizing according to EN ISO 1461;

Fixation System

Type A – Standard fixing system composed of metal base embedded in the ground and cast with concrete;

Screws and accessories

Screws: Zinc-plated steel or optionally AISI 304 stainless steel;

Capsules: PP polypropylene plastic;



100%

 **PROTECTORES DECORATIVOS:**



Penetra profundamente na madeira destacando os veios e embelezando a madeira com as suas cores especiais transparentes



Muito resistente ao sol. Contém pigmentos micronizados absorventes e estabilizadores dos raios UV.



Microporos, deixa respirar a madeira e evita as deformações naturais da madeira.

PRINCÍPIOS ACTIVOS



Fácil manutenção. Não é necessário lixar ou decapar para a aplicação de novas camadas.



Conferindo ao filme uma barreira protectora contra fungos e bolores



HIDRÓFUGO
protege contra a humidade, a chuva e impermeabiliza.





Fun: While having fun, children acquire immense abilities, from physical abilities to social interactions.



Socializing: Socialization and imagination are necessary throughout the game. All this creates a relationship between children and awakens the sense of coexistence and solidarity.



Play: Develops patience, sharing and sporting spirit.



Climb: It develops children's motor skills, body control, balance and coordination, stimulating motor ability and strength in movements.



Glide: This activity provides a fascinating feeling which in turn helps to develop balance and coordination by stimulating the nervous system.



Sliding: The sloping surface allows the child to slide at high speed. The sensation of speed makes you feel alive and learn to control your movements by exercising reflexes and motor skills.



Poteaux

Bois: Pin stratifié classé avec une qualité garantie par contrôle interne continu.

Avec traitement autoclave, le protégeant des attaques de champignons, d'insectes et de termites. Finition de peinture à base d'eau spécialement développée pour protéger le bois contre l'humidité, les intempéries et les rayons UV. Contient des principes actifs qui lui confèrent une barrière protectrice contre l'apparition de champignons et de moisissures;

Panneaux

HDPE: Polyéthylène haute densité mono ou bicolore. Être un polymère se caractérise par sa résistance aux produits chimiques et à la corrosion. Grâce à son élasticité et à sa légèreté, il offre une grande résistance aux chocs et est très difficile à briser. La surface antidérapante assure la sécurité des enfants et sa base synthétique empêche la croissance des bactéries et des champignons. Il ne nécessite aucun entretien

Filet

cordes Ø16mm renforcées en acier recouvertes de fibres de polypropylène, raccords et raccords en plastique HDPE avec protection anti-UV, éléments de fixation en acier galvanisé à chaud;

Contreplaqué Marine

anti-dérapant, collé avec des résines phénoliques résistantes aux intempéries et aux rayons UV. conforme aux normes EL 314-2 / classe 3 (DIN 68 TS TCIL3: BFU 100, BS 6566 PARTIE 8: WBP);

Pièces en plastique

Tunnel: En tube ondulé en polypropylène conforme à la norme EN 13476;

Pièces métalliques

Tubes:

Surface coulissante: plaque en acier inoxydable AISI 304, pliée et roulée en une seule pièce;

Acier inoxydable: AISI 304 de Ø40mm et Ø54mm;

Fer: avec traitement anticorrosion de la galvanisation à chaud selon la norme EN ISO 1461;

Système de fixation

Type A – Système de fixation standard composé d'une base en métal noyée dans le sol et coulée avec du béton;

Vis et accessoires

Vis: Acier zingué ou acier inoxydable AISI 304 en option;

Capsules: PP polypropylène plastique;



PROTECTORES DECORATIVOS:



Penetra profundamente na madeira destacando os veios e embelezando a madeira com as suas cores especiais transparentes



Muito resistente ao sol. Contém pigmentos microcristalinos absorventes e estabilizadores dos raios UV.



Microporos, deixa respirar a madeira e evita as deformações naturais da madeira.



PRINCÍPIOS ACTIVOS

Conferindo ao filme uma barreira protectora contra fungos e bolores



HIDRÓFUGO

protege contra a humidade, a chuva e impermeabiliza.



SISTEMAS DE FIXAÇÃO / SISTEMAS DE FIJACIÓN
FIXING SYSTEMS / SYSTÈMES DE FIXATION



Amusement: tout en s'amusant, les enfants acquièrent d'énormes capacités, allant des capacités physiques aux interactions sociales.



Socialiser: la socialisation et l'imagination sont nécessaires tout au long du jeu. Tout cela crée une relation entre les enfants et éveille le sentiment de coexistence et de solidarité.



Jouer: Développe la patience, le partage et l'esprit sportif.



Escalade: Il développe les capacités motrices, le contrôle du corps, l'équilibre et la coordination des enfants, stimulant la capacité motrice et la force dans les mouvements.



Glide: Cette activité procure une sensation fascinante qui aide à développer l'équilibre et la coordination en stimulant le système nerveux.



Coulissante: la surface inclinée permet à l'enfant de glisser à grande vitesse. La sensation de vitesse vous permet de vous sentir vivant et d'apprendre à contrôler vos mouvements en exerçant des réflexes et des habiletés motrices.