

HANDPAN

EldrUM001

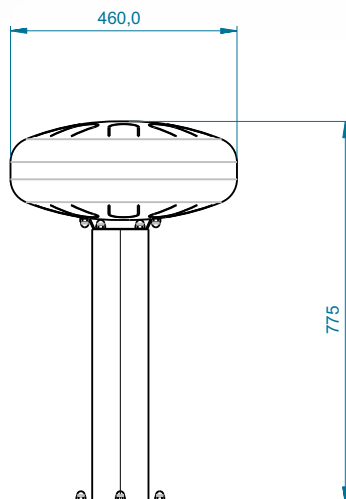
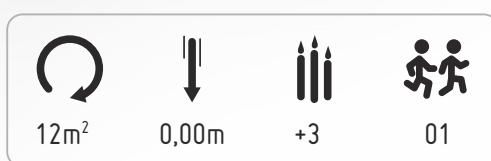

— Zona de impacto
 - - Espaço livre

EN 1176-1,3

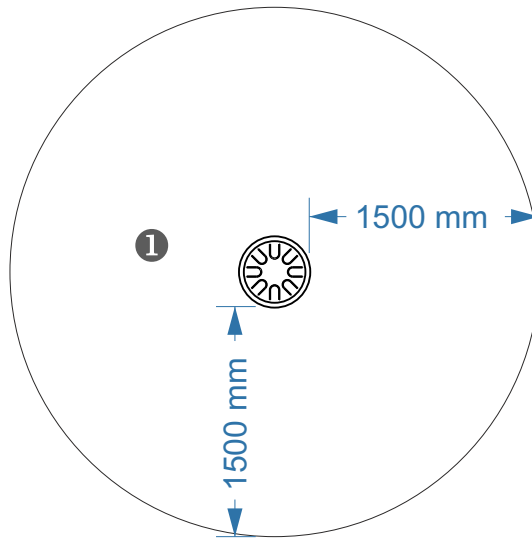

.....	①
	0,00
	12
	12

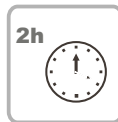
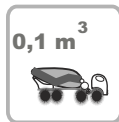

INFORMAÇÃO TÉCNICA / INFORMACIÓN TÉCNICA / TECHNICAL INFORMATION / INFORMATIONS TECHNIQUES

1 - Handpan

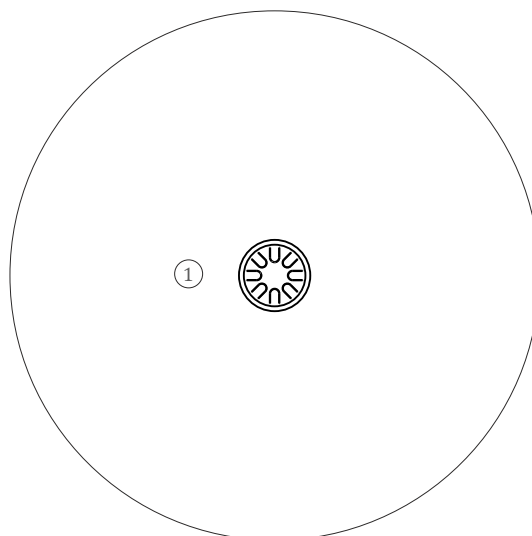



Peças Metálicas

Ferro: Aço carbono S235JR/S275, laminado a quente;

Tratamentos de Superfícies

Galvanização: Tratamento anticorrosivo de galvanização por imersão a quente espessura entre 100 a 140µm de acordo com a norma EN ISO 1461.

Decapagem: Processo por jato abrasivo para limpeza da superfície metálica de oxidações e impurezas, garantindo um perfil de rugosidade ideal para o processo de tratamento de superfície; de acordo com a norma 8501:1;

Primário: A epóxi de poliéster anticorrosivo, ecológico com proteção de nível C4, com cozedura a 210°C;

Lacagem: Pintura electrostática a tinta em pó de poliéster com cozedura 230°C, espessura entre 100 a 120µm, de acordo com a norma UNE EN ISO 2808;

Negativo

Tipo B – Sistema de fixação composto por base metálica aparafusada ao solo;

Ferragens e acessórios

Ferragens: Aço zincado ou opcionalmente em aço inox A1 ou A2;

Cápsulas: Plástico polipropileno PP;



FUNÇÕES LÚDICAS/ FUNCIONES LÚDICAS / RECREATIONAL FUNCTIONS / FONCTIONS RÉCRÉATIVES



Divertir

Enquanto se divertem, as crianças adquirem imensas capacidades, desde habilidades físicas a interações sociais.



Socializar

A socialização e a imaginação são necessárias em todo o jogo. Tudo isso cria relação entre crianças e desperta o senso de convivência e a solidariedade.



Jogar

Desenvolve a paciência, a partilha e o espírito desportivo.



Piezas Metálicas

Hierro: Acero carbono S235JR/S275, laminado en caliente.

Tratamientos de Superficies

Galvanización: Tratamiento anticorrosivo de galvanización por inmersión en caliente. Espesor entre 100 a 140µm de acuerdo con la norma EN ISO 1461.

Decapado: Proceso por chorro abrasivo para limpieza de la superficie metálica de oxidaciones e impurezas, garantizando un perfil de rugosidad ideal para el proceso de tratamiento de superficie; de acuerdo con la norma 8501:1;

Primario: La epoxi de poliéster anticorrosiva, ecológica con protección de nivel C4, con una cocción a 210°C;

Lacado: Pintura electroestática con pintura en polvo de poliéster con una cocción a 230°C, espesor entre 100 a 120µm, de acuerdo con la norma UNE EN ISO 2808;

Negativo

Tipo B – Sistema de fijación estándar compuesto por pletina metálica atornillada a la base de hormigón.

Herrajes y Accesorios

Herrajes: Acero cincado u opcionalmente en acero inox A1 o A2.

Cápsulas: Plástico polipropileno PP.



FUNÇÕES LÚDICAS/ FUNCIONES LÚDICAS / RECREATIONAL FUNCTIONS / FONCTIONS RÉCRÉATIVES



Divertir

Mientras se divierten, los niños adquieren inmensas capacidades, desde habilidades físicas a interacciones sociales.



Socializar

La socialización y la imaginación son necesarias en todo el juego. Todo esto crea relación entre niños y despierta el sentido de convivencia y la solidaridad.



Jugar

Desarrolla la paciencia, el compartir y el espíritu deportivo.



Metal parts

Iron: S235JR / S275 carbon steel, hot rolled;

Surface Treatments

Galvanization: Anti-corrosion treatment of hot-dip galvanization between 100 and 140 µm, according to EN ISO 1461;

Pickling: Abrasive jet process for cleaning the metal surface from oxidation and impurities, ensuring an ideal roughness profile for the surface treatment process; according to standard 8501: 1;

Primer: Ecological anti-corrosion polyester epoxy with protection level C4, with cooking at 210°C;

Powder Coating: Electrostatic painting in polyester powder paint with 230°C cooking, thickness between 100 to 120µm, according to UNE EN ISO 2808;

Anchoring

Type B: Fixing system made up of a metal base screwed to the ground;

Hardware and accessories

Hardware: Galvanized steel or optionally A1 or A2 stainless steel;

Capsules: PP polypropylene plastic;



Fun

While having fun, children acquire immense abilities, from physical abilities to social interactions.



Socializing

Socialization and imagination are necessary throughout the game. All this creates a relationship between children and awakens the sense of coexistence and solidarity.



Play

Develops patience, sharing and sporting spirit.

Pièces Métalliques

Fer : acier au carbone S235JR / S275, laminé à chaud ;

Traitements de surface

Galvanisation : Traitement anti-corrosion de la galvanisation à chaud entre 100 et 140 µm selon EN ISO 1461.

Décapage : Procédé par jet abrasif pour nettoyer la surface métallique de l'oxydation et des impuretés, assurant un profil de rugosité idéal pour le processus de traitement de surface ; selon la norme 8501:1;

Primaire : Epoxy polyester anti-corrosion écologique avec niveau de protection C4, avec cuisson à 210°C;

Laquage : Peinture électrostatique en peinture poudre polyester avec cuisson 230°C, épaisseur entre 100 et 120µm, selon UNE EN ISO 2808;

Négatif

Type B – Système de fixation composé d'une base métallique vissée au sol;

Quincaillerie et accessoires

Matériel : acier galvanisé ou éventuellement acier inoxydable A1 ou A2;

Capsules : plastique polypropylène PP;



Amusement

Tout en s'amusant, les enfants acquièrent d'immenses capacités, des capacités physiques aux interactions sociales.



Socialiser

La socialisation et l'imagination sont nécessaires tout au long du jeu. Tout cela crée une relation entre les enfants et éveille le sens de la coexistence et de la solidarité.



Jeu

Développe la patience, le partage et l'esprit sportif.