

TECTUM

ELTEC001-Y

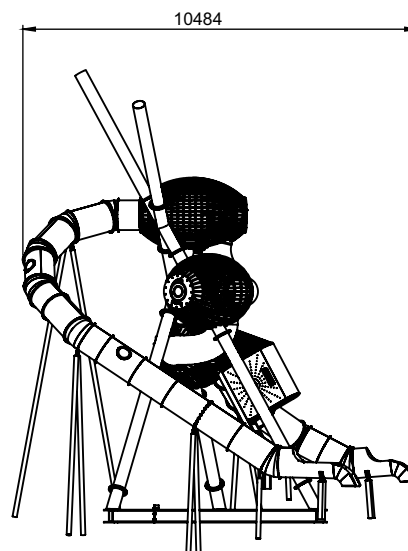

112m ²	2,50m	3-14	35

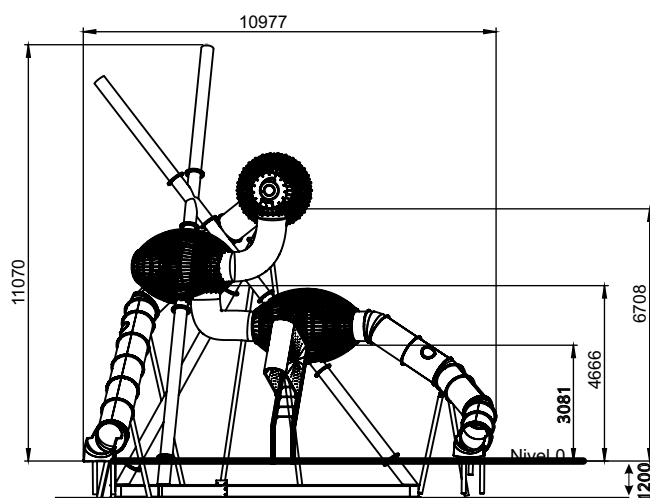

Utilização do equipamento sujeito a condições vigiadas; Zona de segurança: Área mínima requerida pela norma EN 1176-1,3
 Utilización del equipo sujeto a condiciones vigiladas; Zona de seguridad: Área mínima requerida por la norma EN 1176-1,3
 Use of equipment subject to supervised conditions; Safety zone: Minimum area required by EN 1176-1,3
 Utilisation d'équipement soumis à des conditions supervisées; Zone de sécurité: Surface minimale requise par l'EN 1176-1,3



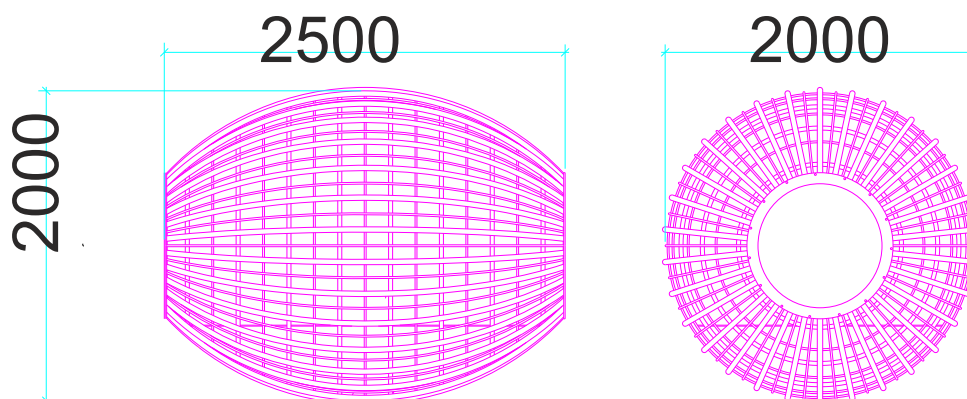

Escada | Escalera | Stairs | Échelle

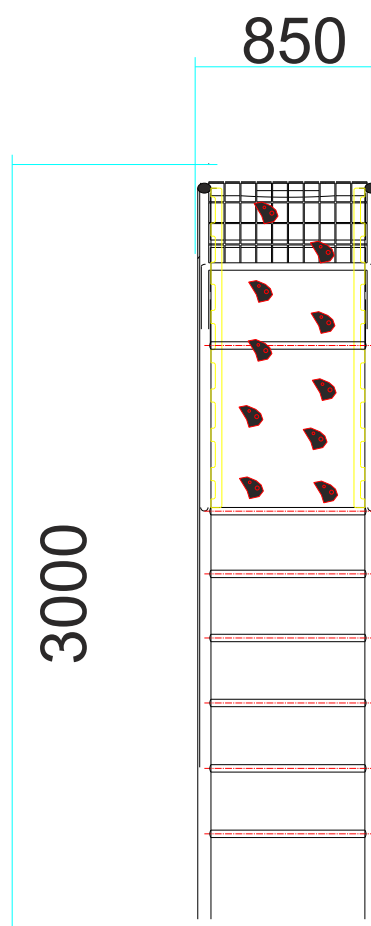

Ecorregas | Toboganes | Slides | Tobogan

Altura máxima | Altura máxima | Maximum height | Hauteur maximale

1-3700mm



2-7000mm

— Zona de impacto

- - Espacio libre

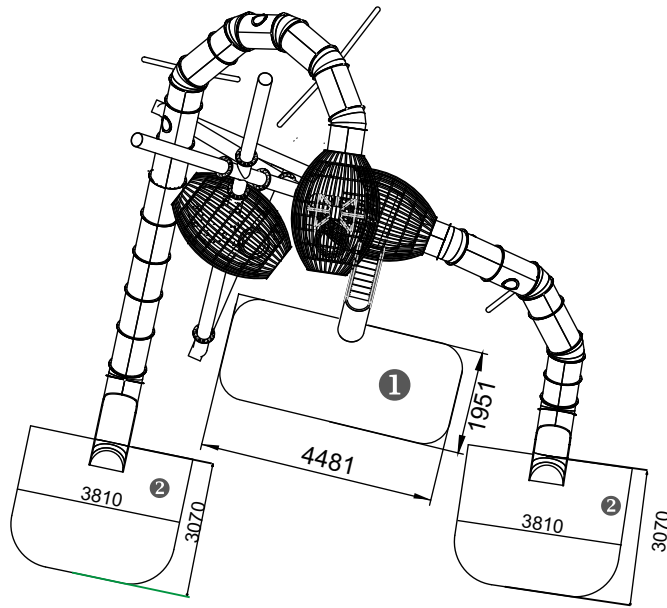
EN 1176-1,3





----	①
	0.90
	112

1.84m³



20h



2x







KG



KG



- 1 - Escorrega Inox  2.50m
- 2 - Escorrega Inox  4.98m
- 3 - Torre Oval  0.50m
- 4 - Torre Oval  2.50m
- 5 - Torre Oval  4.98m

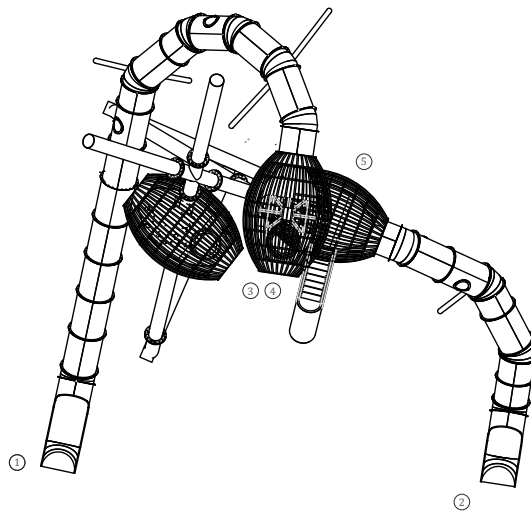



Painéis

HDPE: Polietileno de alta densidade monocolor ou bicolor. Por ser um polímero é caracterizado pela sua resistência a produtos químicos e à corrosão. Pela sua capacidade de elasticidade e leveza, oferece alta resistência ao impacto, sendo muito difícil quebrar. A superfície antiderrapante fornece segurança para as crianças e a sua base sintética impede o cultivo de bactérias e fungos. Não necessita de qualquer manutenção;

Acrílico

composto de 70% de fibras de coníferas e 30% de resina termofixa, resistente às intempéries (sol, chuva, humidade, etc.);

Peças de Plástico

Túnel: PRFV: Material composto, de matriz polimérica e revestido de fibra de vidro;

Peças Metálicas

Escorregas: Aço AISI 304, dobrado.

Tubos Estrutural :Tubos de 324x10mm, esmalte tipo gel a 230°C, com espessura de 50 a 70µm.

Estruturas Ovais: Tubo de ferro, acabamento esmalte tipo gel a 230°C, com espessura entre 50 a 70µm.

Sistema de fixação

Tipo Y – Sistema de fixação standard composto por prumo aplicado directamente no solo e chumbado com betão;

Parafusos e acessórios

Parafusos: Aço zincado ou opcionalmente aço inox AISI 304;

Câpsulas: Plástico polipropileno PP;





Divertir: Enquanto se divertem, as crianças adquirem imensas capacidades, desde habilidades físicas a interações sociais.



Socializar: A socialização e a imaginação são necessárias em todo o jogo. Tudo isso cria relação entre crianças e desperta o senso de convivência e a solidariedade.



Jogar: Desenvolve a paciência, a partilha e o espírito desportivo.



Trepar: Desenvolve as capacidades motrizes das crianças, o controlo do próprio corpo, o equilíbrio e a coordenação, estimulando a capacidade motora e a força nos movimentos.



Escorregar: A superfície inclinada permite que a criança deslize a grande velocidade. A sensação de velocidade fá-la sentir viva e a aprender a controlar os movimentos exercitando os reflexos e as habilidades motoras.



Paneles

HDPE: Polietileno de alta densidad, monocolor o bicolor. Al tratarse de un polímero, su resistencia a productos químicos y corrosión está garantizada. Su capacidad de elasticidad y levedad ofrece una alta resistencia a cualquier tipo de impacto, siendo muy difícil que se produzcan roturas. Su superficie antideslizante ofrece a los niños una alta seguridad y su base sintética impide el desarrollo de bacterias y hongos. No necesita ningún tipo de mantenimiento.

Acrílico

Compuesto por un 70% de fibras coníferas y un 30% de resina termofija resistente a inclemencias del tiempo (sol, lluvia, humedad, etc.)

Piezas de plástico

Túnel: PRFV: Material compuesto, de matriz polimérica y revestido de fibra de vidrio;

Piezas metálicas

Tobogán: Aço AISI 304, doblado.

Tubos Estructural :Tubos de 324x10mm, esmalte tipo gel a 230°C, con espesor de 50 a 70µm. Estructuras Ovais: Tubo de hierro, acabado esmalte tipo gel a 230°C, con espesor de 50 a 70µm.

Sistema de fijación

TIPO Y – Sistema de fijación estándar compuesto por poste hormigonado directamente en el suelo.

Tornillería y accesorios

Tornillos: Acero galvanizado electrolítico u opcionalmente acero inoxidable AISI 304;

Cápsulas: Plástico de polipropileno PP;





Divertir: Los niños, mientras se divierten, desarrollan una parte importante de sus capacidades, ya sean físicas, psicomotoras hasta interacciones sociales.



Socializar: Desarrollar la Socialización e imaginación son capacidades necesarias en los juegos de los niños; lo que conlleva a una relación interactiva entre ellos, despertando su sentido de convivencia y solidaridad.



Jugar: Desarrolla la tolerancia, el aprender a compartir, así como su espíritu deportivo.



Trepar: Se trata de un ejercicio idóneo para el desarrollo de las habilidades motrices de los niños, del control de su propio cuerpo, equilibrio y coordinación; estimulando, de esta manera, su capacidad motora y la seguridad en sus movimientos.



Deslizarse: La superficie inclinada de ciertos aparatos lúdicos permite que el niño se deslice a una determinada velocidad; sensación que le va a permitir experimentar ciertas sensaciones en cuanto aprende a controlar sus movimientos, ejercitando reflejos inmediatos y desarrollando su psicomotricidad.



Panels

HDPE: Monocolor or bicolor high density polyethylene. As a polymer it is characterized by its resistance to chemicals and corrosion. Due to its elasticity and lightness, it offers high impact resistance and is very difficult to break. The non-slip surface provides safety for children and its synthetic base prevents the growth of bacteria and fungi. It does not need any maintenance;

Acrylic

70% conifer fiber and 30% thermoset resin, weather resistant (sun, rain, humidity, etc.);

Plastic parts

Tunnel: GRP: Composite material, polymeric matrix and coated with fiberglass;

Metallic Parts

Slides: AISI 304 steel, folded.

Structural Tubes: 324x10mm tubes, gel enamel at 230°C, with a thickness of 50 to 70µm.

Oval Structures: Iron tube, gel enamel finish at 230°C, with a thickness between 50 and 70µm.

Fixation System

Type Y – Standard fixing system composed of plumb applied directly to the ground and anchored with concrete;

Screws and accessories

Screws: Zinc plated steel or optionally AISI 304 stainless steel;

Capsules: PP polypropylene plastic;





Fun: While having fun, children acquire immense abilities, from physical abilities to social interactions.



Socialize: Socialization and imagination are necessary throughout the game. All this creates a relationship between children and awakens the sense of coexistence and solidarity.



Play: Develops patience, sharing and sporting spirit.



Climb: It develops children's motor skills, body control, balance and coordination, stimulating motor ability and strength in movements.



Slide: The sloping surface allows the child to slide at high speed. The sensation of speed makes them feel alive and learn to control their movements by exercising reflexes and motor skills.

Panneaux

PEHD: polyéthylène haute densité monocolor ou bicolor. En tant que polymère, il se caractérise par sa résistance aux produits chimiques et à la corrosion. En raison de son élasticité et de sa légèreté, il offre une résistance élevée aux chocs et est très difficile à casser. La surface antidérapante offre une sécurité pour les enfants et sa base synthétique empêche la croissance des bactéries et des champignons. Il ne nécessite aucun entretien.

Acrylique

70% de fibres de conifères et 30% de résines thermodurcissables, résistantes aux intempéries (soleil, pluie, humidité, etc.):

Pièces en plastique

Tunnel: GRP: Matériau composite, matrice polymère et enduit de fibre de verre;

Pièces métalliques

Glissades: acier AISI 304, plié.

Tubes structuraux: tubes de 324 x 10 mm, gel émaillé à 230 ° C, d'une épaisseur de 50 à 70 µm.

Structures ovales: Tube en fer, gel émaillé à 230°C, d'une épaisseur comprise entre 50 et 70µm.

Système de fixation

Type Y – Système de fixation standard composé d'aplomb appliqué directement au sol et ancré au béton;

Vis et accessoires

Vis: acier galvanisé ou acier inoxydable AISI 304 en option;

Capsules: polypropylène PP;





Amuser: tout en s'amusant, les enfants acquièrent d'énormes capacités, allant des capacités physiques aux interactions sociales.



Socialiser: la socialisation et l'imagination sont nécessaires tout au long du jeu. Tout cela crée une relation entre les enfants et éveille le sentiment de coexistence et de solidarité.



Jouer: Développe la patience, le partage et l'esprit sportif.



Escalader: développe les capacités motrices, le contrôle du corps, l'équilibre et la coordination des enfants, stimulant la capacité motrice et la force dans les mouvements.



Glisser: la surface inclinée permet à l'enfant de glisser à grande vitesse. La sensation de vitesse permet de se sentir vivant et d'apprendre à contrôler les mouvements en exerçant des réflexes et des habiletés motrices.