

Tolerância Geral: $\pm 5\%$



PORTUGAL
www.bragmaia.com
geral@bragmaia.com

brag
PLAY

brag
URBAN

brag
SPORT

brag
SIGN

brag
LIGHT

MEDIDAS GERAIS / MEDIDAS / MEASURES / MESURES



0,90m³



00:30h



0x



0,00kg



28,00kg

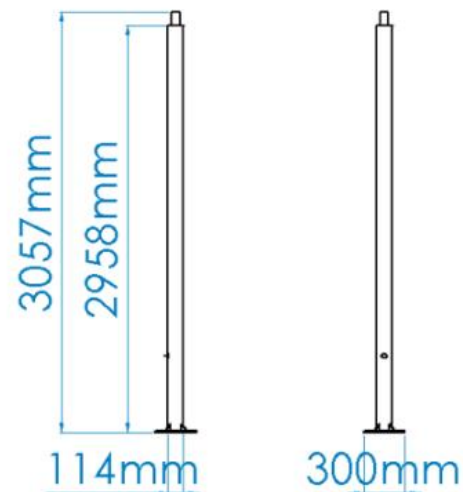

PORTUGAL
www.bragmaia.com
geral@bragmaia.com

brag
PLAY





brag
URBAN

brag
SPORT

brag
SIGN

brag
LIGHT

ACESSÓRIOS / ACCESORIOS / ACCESSORIES / ACCESSOIRES

8,0 x		093422160000	PORCA SEXTAVADA ACO ZINC.D934 M16
8,0 x		902112160000	ANILHA ABA LARGA DIN9021 FE ZN M16
1,0 x		CLM16500100Z	CHUMBADOURO EM "L" M16 500X100MM COM ROSCA 150MM EM ACO S275 ZINCADO
1,0 x		PIDEPGEL2601804	CHAPA GALVA 300X300X1.8MM 4F Ø18MM

VARIANTES / VARIANTES / VARIANTS / VARIANTES

	CT40	COLUNA CILINDRICA DIAM.120MM GALVANIZADA C/4MTS
--	------	---



PORTUGAL
www.bragmaia.com
geral@bragmaia.com

brag PLAY brag URBAN brag SPORT brag SIGN brag LIGHT



DESCRIÇÃO

Equipamento BraglLU, coluna CILÍNDRICA, composto por estrutura em tubo com Ø114mm Ø40mm em aço carbono decapado. Tratamento primário à base de zinco C5 e acabamento lacado ao RAL cinza forja 600 deep blue, à temperatura de 230°C.
Tubo de fixação com Ø60mm.

Medidas gerais (CxLxA): 114x300x3057mm

CARACTERÍSTICAS TÉCNICAS



FERRAGENS EM AÇO ELETROZINCADO

Ferragens em aço eletrozincado, protegidas por cápsulas em polipropileno PP.



SISTEMA DE FIXAÇÃO

Tipo Y - Sistema de fixação composto por base metálica embutida ou por prumos aplicado diretamente no solo e chumbada com betão.

A base metálica embutida é fabricada em chapa de aço carbono, com tratamento anticorrosivo de galvanização por imersão a quente com espessura entre 120 a 140µm de acordo com a norma EN ISO 1461, que permite a sua colocação sem que o prumo entre em contacto direto com o solo. A sua fixação ao prumo é feita por um sistema de aperto rápido aumentando a longevidade do prumo e a sua fácil e rápida substituição em caso de necessidade.

CONFIDENCIALIDADE E PROPRIEDADE INTELECTUAL

A informação contida neste documento é confidencial, não podendo o destinatário do mesmo reproduzi-la ou permitir a terceiros que a obtenham, utilizem ou divulguem sem a prévia e expressa autorização da BRICANTEL.

Todos os direitos de propriedade intelectual sobre os desenhos e modelos apresentados são da titularidade exclusiva da BRICANTEL, sendo expressamente proibida a prática de qualquer ato de exploração dos mesmos sem o consentimento desta, nos termos do código da propriedade industrial e do código do direito de autor e dos direitos conexos. A violação da obrigação de confidencialidade e/ou dos direitos de propriedade intelectual da BRICANTEL, pode dar origem a responsabilidade civil e criminal.



PORTUGAL
www.bragmaia.com
geral@bragmaia.com



DESCRIPCIÓN

Equipamiento BragILU, columna CILÍNDRICA. Compuesto por una estructura en tubo de Ø114mm y Ø40mm en acero carbono decapado. Tratamiento primario a base de zinc C5 y acabado lacado a RAL gris forja 600 deep blue, a una temperatura de 230°C. Tubo de fijación de Ø60mm.

Medidas generales (LxAnxA): 114x300x3057mm

CARACTERÍSTICAS TÉCNICAS



HERRAJES EN ACERO ELECTROCHAPADO

Herrajes en acero electrochapado, protegidos por cápsulas en polipropileno PP.



SISTEMA DE FIJACIÓN

Tipo Y - Sistema de fijación estándar compuesto por una base metálica o poste embutido al suelo y con relleno de hormigón.

La base metálica incorporada está fabricada en chapa de acero de carbono, con tratamiento anticorrosivo por inmersión en caliente de 120 a 140µm de espesor según EN ISO 1461, que permite su colocación sin que el poste entre en contacto directo con el suelo. Su fijación a al poste se realiza por un sistema de sujeción rápido aumentando la longevidad del poste y su fácil y rápida sustitución en caso de necesidad.

CONFIDENCIALIDAD Y PROPIEDAD INTELECTUAL

La información contenida en este documento es estrictamente confidencial, no pudiendo el destinatario reproducirla o permitir a terceros que la adquieran, utilicen o divulguen sin la previa y expresa autorización de BRICANTEL.

Todos los derechos de propiedad intelectual sobre los diseños y modelos presentados son de titularidad exclusiva de BRICANTEL, estando expresamente prohibida la práctica de cualquier acto de usurpación de los mismos sin el previo consentimiento de la empresa, dentro de los términos del código de propiedad industrial y del código de derechos de autor y derechos análogos. La violación de la obligación de confidencialidad y/o de los derechos de propiedad intelectual de BRICANTEL, puede dar origen a responsabilidad civil y criminal.



PORTUGAL
www.bragmaia.com
geral@bragmaia.com

brag
PLAY

brag
URBAN

brag
SPORT

brag
SIGN

brag
LIGHT



DESCRIPTION

BragURBAN equipment, Cylindrical column, composed of pickled carbon steel tube of Ø114mm and Ø40mm. Primary treatment based on C5 zinc and powder coated to RAL 600 Deep Blue, at the temperature of 230°C. Fixation tube with Ø60mm.

General measures (LxWxH): 114x300x3057mm

TECHNICAL FEATURES



STEEL ELECTROPLATED HARDWARE

Steel electroplated hardware, protected by polypropylene PP capsules.



FIXATION SYSTEM

Type Y - Fixation system composed of built-in metal base or plumbing applied directly to the ground and concrete sinker.

The built-in metal base is made of carbon steel sheet, with corrosion-resistant hot-dip galvanisation treatment of between 120 and 140µm thickness according to EN ISO 1461, which allows its placement without the plumb in direct contact with the ground. Its attachment to the plumb line is made by a quick clamping system increasing the longevity of the plumb line and its easy and fast replacement in case of need.

CONFIDENTIALITY AND INTELLECTUAL PROPERTY

The information contained in this document is confidential, and the recipient cannot reproduce it or allow third parties to obtain, use or disclose it without the prior and express authorization of BRICANTEL.

All intellectual property rights over the designs and models presented are the exclusive property of BRICANTEL, and the practice of any act of exploitation thereof without the consent of the latter, under the terms of the industrial property code and the copyright code and related rights. Violation of BRICANTEL's obligation of confidentiality and / or intellectual property rights may give rise to civil and criminal liability.



PORTUGAL
www.bragmaia.com
geral@bragmaia.com

brag
PLAY

brag
URBAN

brag
SPORT

brag
SIGN

brag
LIGHT

DESCRIPTION

Équipement BragILU, Colonne cylindrique, constituée d'une structure tubulaire Ø114mm et Ø40mm en acier au carbone décapé, avec traitement primaire au zinc base C5 et finition laqué en gris forgé RAL 600 bleu foncé, à une température de 230°.

Mesures générales (LxlxH): 114x300x3057mm

CARACTÉRISTIQUES TECHNIQUES



FERRURES EN ACIER ELECTROZINGÉ

Ferrures en acier electrozingué, protégé para des capsules en polypropylène PP.



SISTÈME DE FIXATION

Type Y - Système de fixation composé d'une base métallique encastrée ou d'une poutre appliquée directement au sol et bétonnée.

La base métallique encastrée est fabriquée en tôle d'acier carbone, avec un traitement anticorrosion par galvanisation par immersion à chaud d'une épaisseur comprise entre 120 et 140µm selon la norme EN ISO 1461, qui permet sa pose sans que la poutre rentre en contact direct avec le sol. Sa fixation à la poutre est réalisée par un système de serrage rapide augmentant sa longévité et facilitant son remplacement, qui sera rapide en cas de besoin.

CONFIDENTIALITÉ ET PROPRIÉTÉ INTELLECTUELLE

Les informations contenues dans ce document sont confidentielles et le destinataire ne peut pas les reproduire ni permettre à des tiers de les obtenir, de les utiliser ou de les divulguer sans l'autorisation préalable et expresse de BRICANTEL.

Tous les droits de propriété intellectuelle sur les dessins et modèles présentés sont propriété exclusive de BRICANTEL, et la pratique d'un acte d'exploitation de ceux-ci sans le consentement de cette dernière, selon les termes du code de la propriété industrielle et du code du droit d'auteur et des droits voisins. La violation de l'obligation de confidentialité et / ou des droits de propriété intellectuelle de BRICANTEL peut engager à la responsabilité civile et pénale.



PORTUGAL
www.bragmaia.com
geral@bragmaia.com

brag
PLAY

brag
URBAN

brag
SPORT

brag
SIGN

brag
LIGHT