

# PSYCHE 2

ELDAN060Q

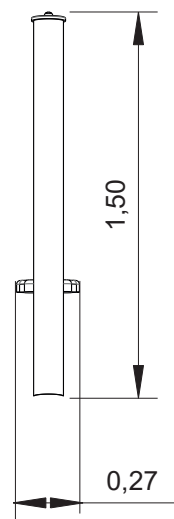

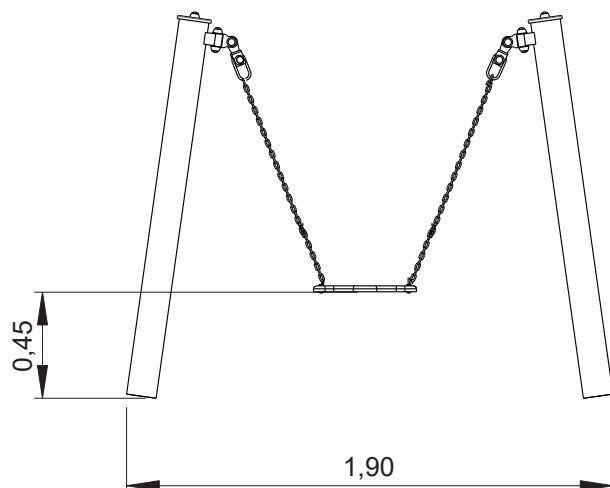

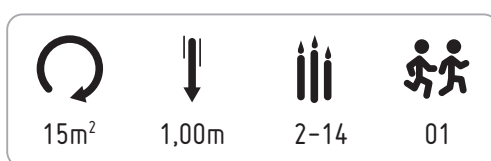

Utilização do equipamento sujeito a condições vigiadas; Zona de segurança: Área mínima requerida pela norma EN 1176-1,6  
 Utilización del equipo sujeto a condiciones vigiladas; Zona de seguridad: Área mínima requerida por la norma EN 1176-1,6  
 Use of equipment subject to supervised conditions; Safety zone: Minimum area required by EN 1176-1,6  
 Utilisation d'équipement soumis à des conditions supervisées; Zone de sécurité: Surface minimale requise par l'EN 1176-1,6

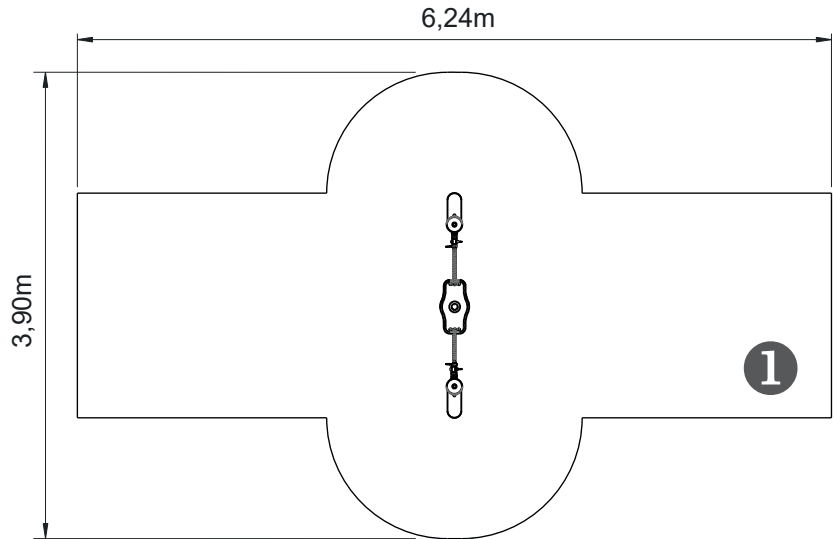

— Zona de impacto  
 - - Espaço livre

EN 1176-1,2 



.....	①
	1.0
	15
	15

0,16 m<sup>3</sup>  



2h  

2x  

KG  

KG  

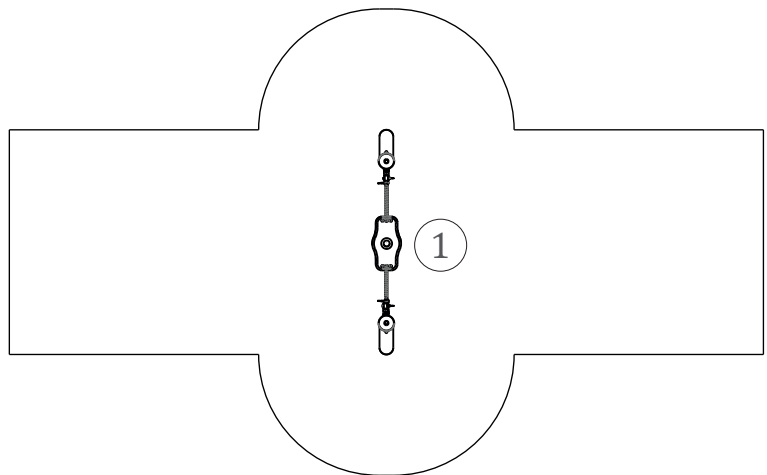
1 - Assento  0.45m





Cadeiras e assentos: Em borracha EPDM injetada, com reforço interior de alumínio. Correntes com  $\varnothing 5\text{mm}$  em aço galvanizado a quente;

#### Peças Metálicas

Tubos: Ferro com tratamento anticorrosivo de galvanização por imersão a quente de acordo com a norma EN ISO 1461;

Lacagem a esmalte Tipo gel a 230°C, com espessura entre 50 a 70  $\mu\text{m}$ , de acordo com a norma UNE EN ISO 2808;

Sistema de fixação:

Tipo C – Sistema de fixação standard composto por prumo aplicado directamente no solo e chumbado com betão;

Parafusos e acessórios

Parafusos: Aço zincado ou opcionalmente aço inox AISI 304;

Cápsulas: Plástico polipropileno PP;

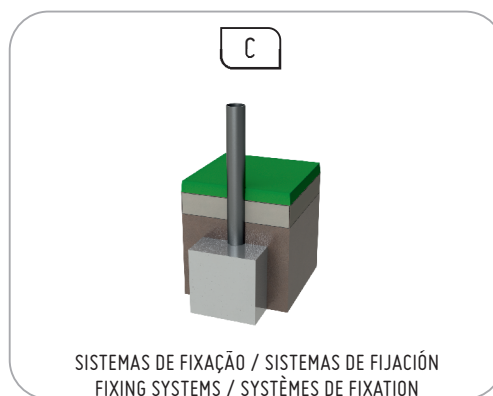

## FUNÇÕES LÚDICAS/ FUNCIONES LÚDICAS / RECREATIONAL FUNCTIONS / FONCTIONS RÉCRÉATIVES



### Divertir

Enquanto se divertem, as crianças adquirem imensas capacidades, desde habilidades físicas a interações sociais.



### Socializar

A socialização e a imaginação são necessárias em todo o jogo. Tudo isso cria relação entre crianças e desperta o senso de convivência e a solidariedade.



### Jogar

Desenvolve a paciência, a partilha e o espírito desportivo.



### Balançar

Este movimento proporciona o desenvolvimento do sistema nervoso, sobretudo ao nível psicomotor e da visão. Para além de ser tranquilizante, desenvolve ainda as capacidades de equilíbrio e coordenação.



Sillas y asientos: En goma EPDM inyectada, con refuerzo interior de aluminio. Cadenas con Ø5mm en acero galvanizado en caliente;

Piezas Metálicas

Tubos: Hierro con tratamiento anticorrosivo de galvanización por inmersión en caliente de acuerdo con la norma EN ISO 1461; Lacado a esmalte Tipo gel a 230°C, con espesor entre 50 y 70µm, de acuerdo con la norma UNE EN ISO 2808;

Sistema de fijación:

Tipo C – Sistema de fijación estándar compuesto por pluma aplicada directamente en el suelo y plomado con hormigón;

Tornillos y accesorios

Tornillos: Acero zincado o opcionalmente acero inoxidable AISI 304;

Cápsulas: Plástico o polipropileno PP;

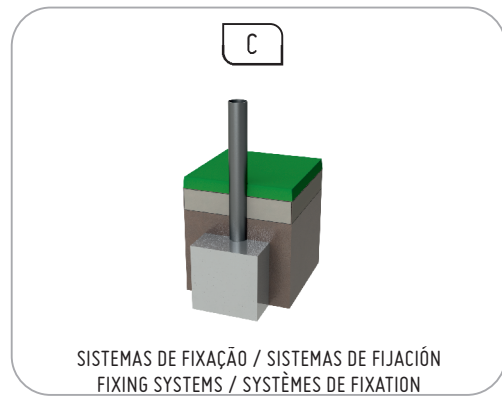

FUNÇÕES LÚDICAS/ FUNCIONES LÚDICAS / RECREATIONAL FUNCTIONS / FONCTIONS RÉCRÉATIVES



Divertir

Mientras se divierten, los niños adquieren inmensas capacidades, desde habilidades físicas a interacciones sociales.



Socializar

La socialización y la imaginación son necesarias en todo el juego. Todo esto crea relación entre niños y despierta el sentido de convivencia y la solidaridad.



Jugar

Desarrolla la paciencia, el compartir y el espíritu deportivo.



oscilación

Este movimiento proporciona el desarrollo del sistema nervioso, sobre todo a nivel psicomotor y de la visión. Además de ser tranquilizante, desarrolla las capacidades de equilibrio y coordinación.



Chairs and seats: In EPDM injected rubber, with aluminum inner reinforcement. Chains with Ø5mm in hot galvanized steel;

Metal parts

Pipes: Hot dip galvanized hot rolled steel according to EN ISO 1461;

Enamel lacquer gel type at 230°C, with a thickness between 50 and 70µm, according to the standard UNE EN ISO 2808;

Fixation System:

Type C - Standard fixing system composed of plumbing applied directly to the ground and cast with concrete;

Screws and accessories

Screws: Zinc-plated steel or optionally AISI 304 stainless steel;

Capsules: PP polypropylene plastic;

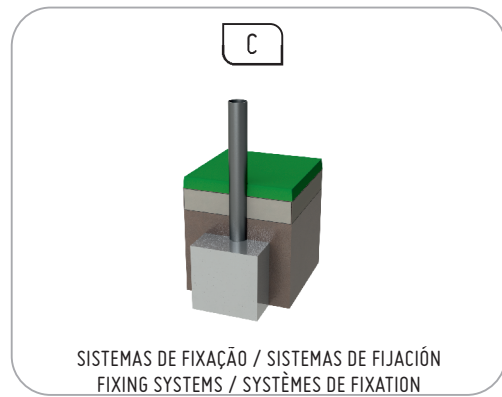

SISTEMAS DE FIXAÇÃO / SISTEMAS DE FIJACIÓN  
FIXING SYSTEMS / SYSTÈMES DE FIXATION



FUNÇÕES LÚDICAS/ FUNCIONES LÚDICAS / RECREATIONAL FUNCTIONS / FONCTIONS RÉCRÉATIVES



Fun

While having fun, children acquire immense abilities, from physical abilities to social interactions.



Socializing

Socialization and imagination are necessary throughout the game. All this creates a relationship between children and awakens the sense of coexistence and solidarity.



Play

Develops patience, sharing and sporting spirit.



To swing

This movement provides the development of the nervous system, especially at the psychomotor and vision level. In addition to being tranquilizer, it also develops the skills of balance and coordination.

Chaises et sièges: En caoutchouc injecté EPDM, avec renfort intérieur en aluminium. Chaînes avec Ø5mm en acier galvanisé à chaud;

Pièces en métal

Tubes: Acier laminé à chaud galvanisé à chaud selon la norme EN ISO 1461;

Gel de type émail à 230°C, d'une épaisseur comprise entre 50 et 70µm, selon la norme UNE EN ISO 2808;

Système de fixation:

Type C - Système de fixation standard composé de plomberie appliquée directement sur le sol et coulée avec du béton;

Vis et accessoires

Vis: Acier zingué ou acier inoxydable AISI 304 en option;

Capsules: PP polypropylène plastique;

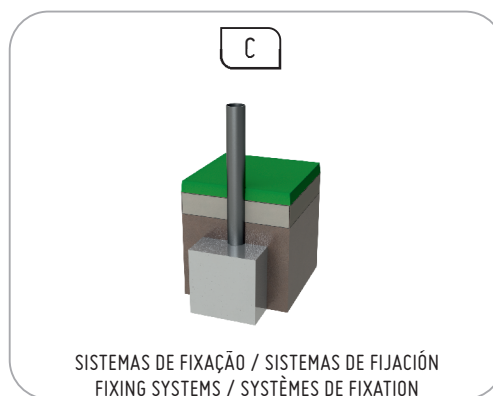

■ ■ FUNÇÕES LÚDICAS/ FUNCIONES LÚDICAS / RECREATIONAL FUNCTIONS / FONCTIONS RÉCRÉATIVES



Amusement

Tout en s'amusant, les enfants acquièrent d'immenses capacités, des capacités physiques aux interactions sociales.



Socialiser

La socialisation et l'imagination sont nécessaires tout au long du jeu. Tout cela crée une relation entre les enfants et éveille le sens de la coexistence et de la solidarité.



Jeu

Développe la patience, le partage et l'esprit sportif.



Balancer

Ce mouvement assure le développement du système nerveux, en particulier au niveau psychomoteur et visuel. En plus d'être tranquilisant, il développe également les compétences d'équilibre et de coordination.